



# wwPDB X-ray Structure Validation Summary Report ⓘ

Apr 20, 2022 – 07:09 pm BST

PDB ID : 7Q38  
Title : Crystal structure of the mutant bacteriorhodopsin pressurized with argon  
Authors : Melnikov, I.; Rulev, M.; Astashkin, R.; Kovalev, K.; Carpentier, P.; Gordeliy, V.; Popov, A.  
Deposited on : 2021-10-27  
Resolution : 1.65 Å(reported)

This is a wwPDB X-ray Structure Validation Summary Report for a publicly released PDB entry.

We welcome your comments at [validation@mail.wwpdb.org](mailto:validation@mail.wwpdb.org)

A user guide is available at

<https://www.wwpdb.org/validation/2017/XrayValidationReportHelp>

with specific help available everywhere you see the ⓘ symbol.

---

The following versions of software and data (see [references ⓘ](#)) were used in the production of this report:

MolProbity : 4.02b-467  
Mogul : 1.8.4, CSD as541be (2020)  
Xtriage (Phenix) : 1.13  
EDS : 2.27  
buster-report : 1.1.7 (2018)  
Percentile statistics : 20191225.v01 (using entries in the PDB archive December 25th 2019)  
Refmac : 5.8.0267  
CCP4 : 7.1.010 (Gargrove)  
Ideal geometry (proteins) : Engh & Huber (2001)  
Ideal geometry (DNA, RNA) : Parkinson et al. (1996)  
Validation Pipeline (wwPDB-VP) : 2.27

# 1 Overall quality at a glance

The following experimental techniques were used to determine the structure:

*X-RAY DIFFRACTION*

The reported resolution of this entry is 1.65 Å.

Percentile scores (ranging between 0-100) for global validation metrics of the entry are shown in the following graphic. The table shows the number of entries on which the scores are based.

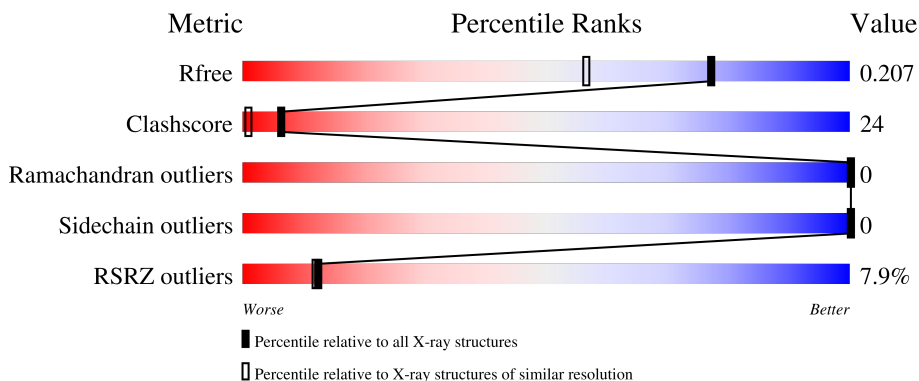

Metric	Whole archive (#Entries)	Similar resolution (#Entries, resolution range(Å))
$R_{free}$	130704	1827 (1.66-1.66)
Clashscore	141614	1931 (1.66-1.66)
Ramachandran outliers	138981	1891 (1.66-1.66)
Sidechain outliers	138945	1891 (1.66-1.66)
RSRZ outliers	127900	1791 (1.66-1.66)

The table below summarises the geometric issues observed across the polymeric chains and their fit to the electron density. The red, orange, yellow and green segments of the lower bar indicate the fraction of residues that contain outliers for  $\geq 3$ , 2, 1 and 0 types of geometric quality criteria respectively. A grey segment represents the fraction of residues that are not modelled. The numeric value for each fraction is indicated below the corresponding segment, with a dot representing fractions  $\leq 5\%$ . The upper red bar (where present) indicates the fraction of residues that have poor fit to the electron density. The numeric value is given above the bar.

Mol	Chain	Length	Quality of chain
1	A	269	

The following table lists non-polymeric compounds, carbohydrate monomers and non-standard residues in protein, DNA, RNA chains that are outliers for geometric or electron-density-fit criteria:

Mol	Type	Chain	Res	Chirality	Geometry	Clashes	Electron density
8	AR	A	326	-	-	-	X

*Continued on next page...*

*Continued from previous page...*

Mol	Type	Chain	Res	Chirality	Geometry	Clashes	Electron density
8	AR	A	329	-	-	X	-
8	AR	A	339	-	-	X	-
8	AR	A	344	-	-	X	-
8	AR	A	345	-	-	X	-
8	AR	A	351	-	-	X	-
8	AR	A	352	-	-	X	-
8	AR	A	353	-	-	X	-
8	AR	A	357	-	-	X	-
8	AR	A	359	-	-	X	-
8	AR	A	360	-	-	X	-
8	AR	A	361	-	-	X	-
8	AR	A	362	-	-	X	-
8	AR	A	365	-	-	X	-
8	AR	A	366	-	-	X	X
8	AR	A	367	-	-	-	X

## 2 Entry composition [i](#)

There are 9 unique types of molecules in this entry. The entry contains 2236 atoms, of which 0 are hydrogens and 0 are deuteriums.

In the tables below, the ZeroOcc column contains the number of atoms modelled with zero occupancy, the AltConf column contains the number of residues with at least one atom in alternate conformation and the Trace column contains the number of residues modelled with at most 2 atoms.

- Molecule 1 is a protein called Bacteriorhodopsin.

Mol	Chain	Residues	Atoms					ZeroOcc	AltConf	Trace
			Total	C	N	O	S			
1	A	228	1821	1242	263	305	11	0	18	0

There are 23 discrepancies between the modelled and reference sequences:

Chain	Residue	Modelled	Actual	Comment	Reference
A	0	MET	-	initiating methionine	UNP P02945
A	17	ALA	THR	engineered mutation	UNP P02945
A	24	ALA	THR	engineered mutation	UNP P02945
A	47	ALA	THR	engineered mutation	UNP P02945
A	250	GLY	-	expression tag	UNP P02945
A	251	SER	-	expression tag	UNP P02945
A	252	GLY	-	expression tag	UNP P02945
A	253	ILE	-	expression tag	UNP P02945
A	254	GLU	-	expression tag	UNP P02945
A	255	GLY	-	expression tag	UNP P02945
A	256	ARG	-	expression tag	UNP P02945
A	257	SER	-	expression tag	UNP P02945
A	258	GLY	-	expression tag	UNP P02945
A	259	ALA	-	expression tag	UNP P02945
A	260	PRO	-	expression tag	UNP P02945
A	261	HIS	-	expression tag	UNP P02945
A	262	HIS	-	expression tag	UNP P02945
A	263	HIS	-	expression tag	UNP P02945
A	264	HIS	-	expression tag	UNP P02945
A	265	HIS	-	expression tag	UNP P02945
A	266	HIS	-	expression tag	UNP P02945
A	267	HIS	-	expression tag	UNP P02945
A	268	HIS	-	expression tag	UNP P02945

- Molecule 2 is RETINAL (three-letter code: RET) (formula: C<sub>20</sub>H<sub>28</sub>O).



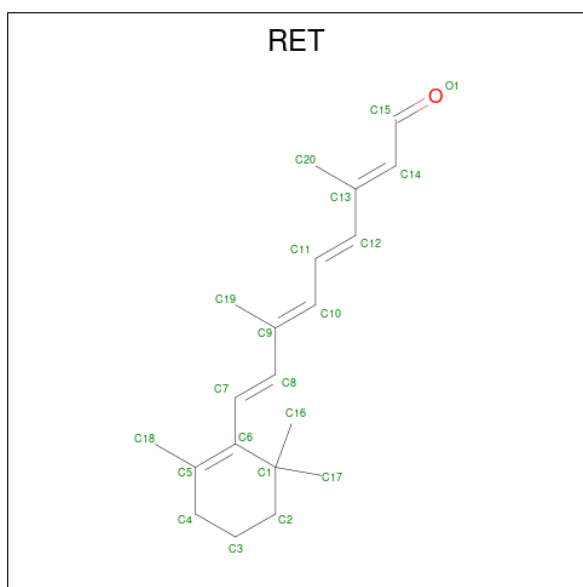

Mol	Chain	Residues	Atoms	ZeroOcc	AltConf
2	A	1	Total C 20 20	0	0

- Molecule 3 is EICOSANE (three-letter code: LFA) (formula:  $C_{20}H_{42}$ ).

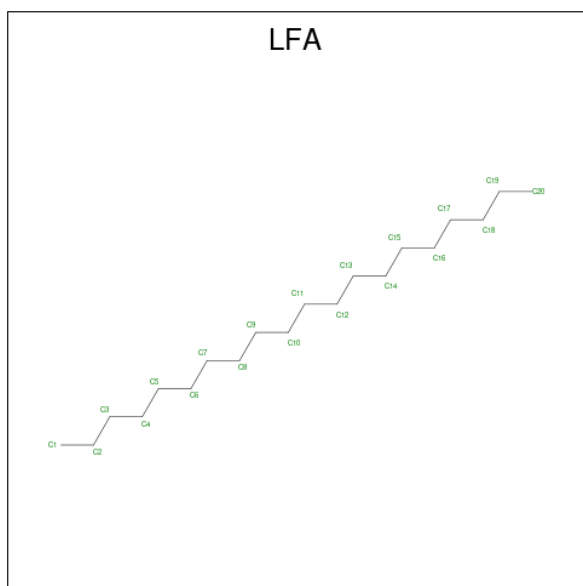

Mol	Chain	Residues	Atoms	ZeroOcc	AltConf
3	A	1	Total C 18 18	0	0
3	A	1	Total C 13 13	0	0
3	A	1	Total C 20 20	0	0

*Continued on next page...*

Continued from previous page...

Mol	Chain	Residues	Atoms	ZeroOcc	AltConf
3	A	1	Total C 18 18	0	0
3	A	1	Total C 7 7	0	0
3	A	1	Total C 6 6	0	0
3	A	1	Total C 10 10	0	0
3	A	1	Total C 11 11	0	0
3	A	1	Total C 9 9	0	0
3	A	1	Total C 11 11	0	0

- Molecule 4 is (2R)-2,3-dihydroxypropyl (9Z)-octadec-9-enoate (three-letter code: OLC) (formula: C<sub>21</sub>H<sub>40</sub>O<sub>4</sub>).

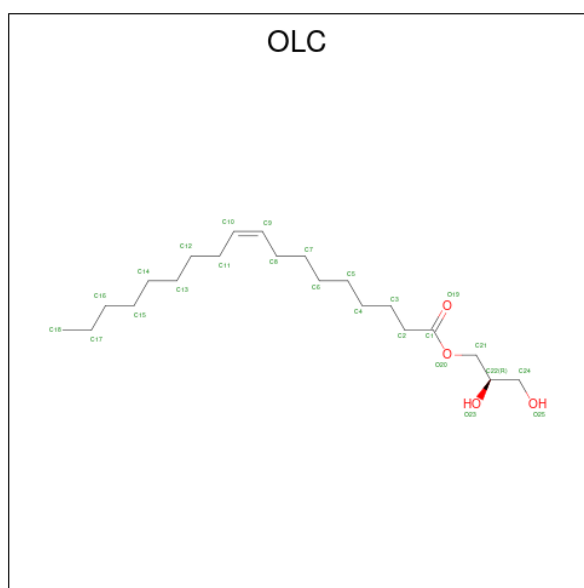

Mol	Chain	Residues	Atoms	ZeroOcc	AltConf
4	A	1	Total C O 20 17 3	0	0

- Molecule 5 is OLEIC ACID (three-letter code: OLA) (formula: C<sub>18</sub>H<sub>34</sub>O<sub>2</sub>).

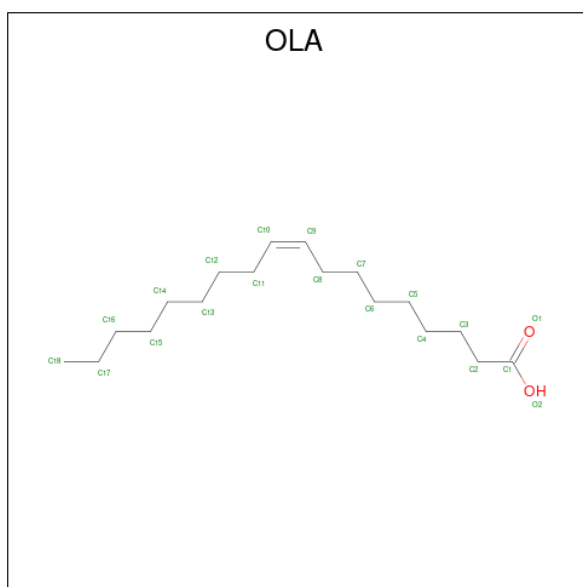

Mol	Chain	Residues	Atoms		ZeroOcc	AltConf
5	A	1	Total	C O	0	0
			20	18 2		
5	A	1	Total	C O	0	0
			19	17 2		
5	A	1	Total	C O	0	0
			15	13 2		

- Molecule 6 is HEXANE (three-letter code: HEX) (formula: C<sub>6</sub>H<sub>14</sub>).

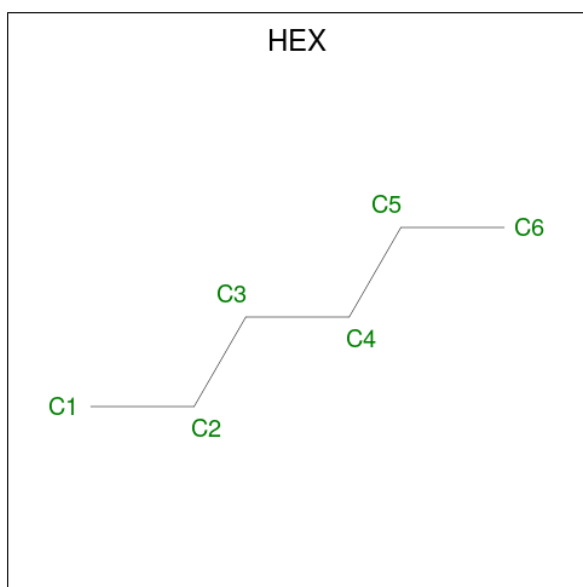

Mol	Chain	Residues	Atoms		ZeroOcc	AltConf
6	A	1	Total	C	0	0
			6	6		

*Continued on next page...*

Continued from previous page...

Mol	Chain	Residues	Atoms	ZeroOcc	AltConf
6	A	1	Total C 6 6	0	0
6	A	1	Total C 4 4	0	0
6	A	1	Total C 6 6	0	0

- Molecule 7 is SULFATE ION (three-letter code: SO4) (formula: O<sub>4</sub>S).

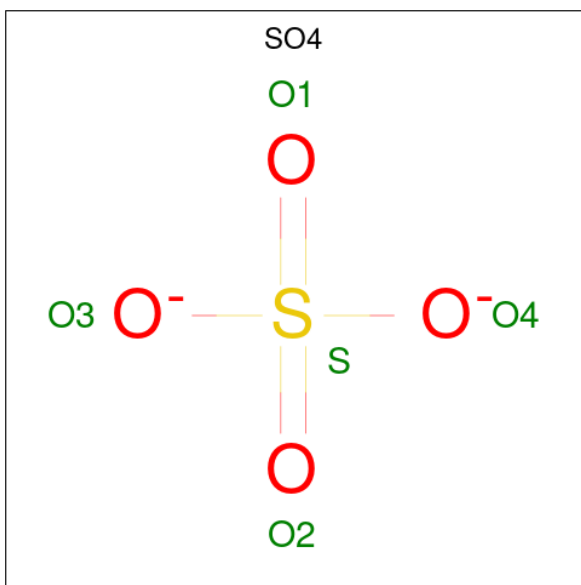

Mol	Chain	Residues	Atoms	ZeroOcc	AltConf
7	A	1	Total O S 5 4 1	0	0
7	A	1	Total O S 5 4 1	0	0

- Molecule 8 is ARGON (three-letter code: AR) (formula: Ar) (labeled as "Ligand of Interest" by depositor).

Mol	Chain	Residues	Atoms	ZeroOcc	AltConf
8	A	47	Total Ar 47 47	0	0

- Molecule 9 is water.

<b>Mol</b>	<b>Chain</b>	<b>Residues</b>	<b>Atoms</b>		<b>ZeroOcc</b>	<b>AltConf</b>
9	A	119	Total 119	O 119	0	0

### 3 Residue-property plots [i](#)

These plots are drawn for all protein, RNA, DNA and oligosaccharide chains in the entry. The first graphic for a chain summarises the proportions of the various outlier classes displayed in the second graphic. The second graphic shows the sequence view annotated by issues in geometry and electron density. Residues are color-coded according to the number of geometric quality criteria for which they contain at least one outlier: green = 0, yellow = 1, orange = 2 and red = 3 or more. A red dot above a residue indicates a poor fit to the electron density ( $RSRZ > 2$ ). Stretches of 2 or more consecutive residues without any outlier are shown as a green connector. Residues present in the sample, but not in the model, are shown in grey.

- Molecule 1: Bacteriorhodopsin

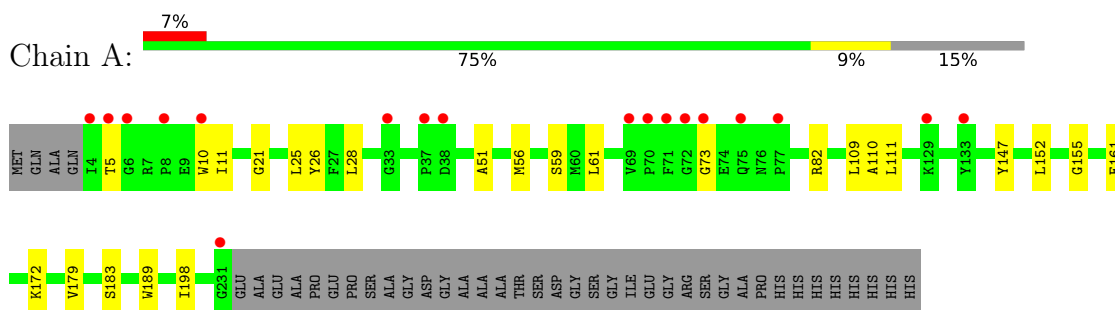

## 4 Data and refinement statistics i

Property	Value	Source
Space group	C 2 2 2	Depositor
Cell constants a, b, c, $\alpha$ , $\beta$ , $\gamma$	115.66Å 119.25Å 36.39Å 90.00° 90.00° 90.00°	Depositor
Resolution (Å)	83.02 – 1.65 83.02 – 1.65	Depositor EDS
% Data completeness (in resolution range)	99.6 (83.02-1.65) 99.6 (83.02-1.65)	Depositor EDS
$R_{merge}$	(Not available)	Depositor
$R_{sym}$	(Not available)	Depositor
$\langle I/\sigma(I) \rangle$ <sup>1</sup>	1.45 (at 1.65Å)	Xtrriage
Refinement program	REFMAC 5.8.0258	Depositor
R, $R_{free}$	0.162 , 0.205 0.176 , 0.207	Depositor DCC
$R_{free}$ test set	1569 reflections (5.10%)	wwPDB-VP
Wilson B-factor (Å <sup>2</sup> )	26.3	Xtrriage
Anisotropy	0.194	Xtrriage
Bulk solvent $k_{sol}$ (e/Å <sup>3</sup> ), $B_{sol}$ (Å <sup>2</sup> )	(Not available) , (Not available)	EDS
L-test for twinning <sup>2</sup>	$\langle  L  \rangle = 0.50$ , $\langle L^2 \rangle = 0.33$	Xtrriage
Estimated twinning fraction	0.015 for -k,-h,-l	Xtrriage
$F_o, F_c$ correlation	0.97	EDS
Total number of atoms	2236	wwPDB-VP
Average B, all atoms (Å <sup>2</sup> )	29.0	wwPDB-VP

Xtrriage's analysis on translational NCS is as follows: *The largest off-origin peak in the Patterson function is 6.82% of the height of the origin peak. No significant pseudotranslation is detected.*

<sup>1</sup>Intensities estimated from amplitudes.

<sup>2</sup>Theoretical values of  $\langle |L| \rangle$ ,  $\langle L^2 \rangle$  for acentric reflections are 0.5, 0.333 respectively for untwinned datasets, and 0.375, 0.2 for perfectly twinned datasets.

## 5 Model quality [i](#)

### 5.1 Standard geometry [i](#)

Bond lengths and bond angles in the following residue types are not validated in this section: OLC, OLA, LFA, HEX, RET, AR, SO4

The Z score for a bond length (or angle) is the number of standard deviations the observed value is removed from the expected value. A bond length (or angle) with  $|Z| > 5$  is considered an outlier worth inspection. RMSZ is the root-mean-square of all Z scores of the bond lengths (or angles).

Mol	Chain	Bond lengths		Bond angles	
		RMSZ	# Z  >5	RMSZ	# Z  >5
1	A	0.76	1/1919 (0.1%)	0.82	0/2621

All (1) bond length outliers are listed below:

Mol	Chain	Res	Type	Atoms	Z	Observed(Å)	Ideal(Å)
1	A	155	GLY	C-O	5.05	1.31	1.23

There are no bond angle outliers.

There are no chirality outliers.

There are no planarity outliers.

### 5.2 Too-close contacts [i](#)

In the following table, the Non-H and H(model) columns list the number of non-hydrogen atoms and hydrogen atoms in the chain respectively. The H(added) column lists the number of hydrogen atoms added and optimized by MolProbity. The Clashes column lists the number of clashes within the asymmetric unit, whereas Symm-Clashes lists symmetry-related clashes.

Mol	Chain	Non-H	H(model)	H(added)	Clashes	Symm-Clashes
1	A	1821	0	1910	56	1
2	A	20	0	27	3	0
3	A	123	0	233	37	0
4	A	20	0	26	11	0
5	A	54	0	81	6	0
6	A	22	0	49	1	0
7	A	10	0	0	0	0
8	A	47	0	0	71	0
9	A	119	0	0	5	0
All	All	2236	0	2326	107	1



The all-atom clashscore is defined as the number of clashes found per 1000 atoms (including hydrogen atoms). The all-atom clashscore for this structure is 24.

The worst 5 of 107 close contacts within the same asymmetric unit are listed below, sorted by their clash magnitude.

Atom-1	Atom-2	Interatomic distance (Å)	Clash overlap (Å)
4:A:312:OLC:O23	8:A:362:AR:AR	1.35	1.80
1:A:109[A]:LEU:HG	8:A:329:AR:AR	1.21	1.76
3:A:309:LFA:C4	8:A:339:AR:AR	1.44	1.61
1:A:109[A]:LEU:CG	8:A:329:AR:AR	1.85	1.58
3:A:309:LFA:C5	8:A:339:AR:AR	1.76	1.56

All (1) symmetry-related close contacts are listed below. The label for Atom-2 includes the symmetry operator and encoded unit-cell translations to be applied.

Atom-1	Atom-2	Interatomic distance (Å)	Clash overlap (Å)
1:A:73:GLY:O	1:A:73:GLY:O[4_556]	1.98	0.22

## 5.3 Torsion angles [i](#)

### 5.3.1 Protein backbone [i](#)

In the following table, the Percentiles column shows the percent Ramachandran outliers of the chain as a percentile score with respect to all X-ray entries followed by that with respect to entries of similar resolution.

The Analysed column shows the number of residues for which the backbone conformation was analysed, and the total number of residues.

Mol	Chain	Analysed	Favoured	Allowed	Outliers	Percentiles
1	A	244/269 (91%)	243 (100%)	1 (0%)	0	<b>100</b> <b>100</b>

There are no Ramachandran outliers to report.

### 5.3.2 Protein sidechains [i](#)

In the following table, the Percentiles column shows the percent sidechain outliers of the chain as a percentile score with respect to all X-ray entries followed by that with respect to entries of similar resolution.

The Analysed column shows the number of residues for which the sidechain conformation was analysed, and the total number of residues.

Mol	Chain	Analysed	Rotameric	Outliers	Percentiles
1	A	190/207 (92%)	190 (100%)	0	100 100

There are no protein residues with a non-rotameric sidechain to report.

Sometimes sidechains can be flipped to improve hydrogen bonding and reduce clashes. There are no such sidechains identified.

### 5.3.3 RNA [i](#)

There are no RNA molecules in this entry.

## 5.4 Non-standard residues in protein, DNA, RNA chains [i](#)

There are no non-standard protein/DNA/RNA residues in this entry.

## 5.5 Carbohydrates [i](#)

There are no monosaccharides in this entry.

## 5.6 Ligand geometry [i](#)

Of 68 ligands modelled in this entry, 47 are monoatomic - leaving 21 for Mogul analysis.

In the following table, the Counts columns list the number of bonds (or angles) for which Mogul statistics could be retrieved, the number of bonds (or angles) that are observed in the model and the number of bonds (or angles) that are defined in the Chemical Component Dictionary. The Link column lists molecule types, if any, to which the group is linked. The Z score for a bond length (or angle) is the number of standard deviations the observed value is removed from the expected value. A bond length (or angle) with  $|Z| > 2$  is considered an outlier worth inspection. RMSZ is the root-mean-square of all Z scores of the bond lengths (or angles).

Mol	Type	Chain	Res	Link	Bond lengths			Bond angles		
					Counts	RMSZ	# Z  > 2	Counts	RMSZ	# Z  > 2
3	LFA	A	304	-	19,19,19	0.35	0	18,18,18	0.21	0
3	LFA	A	308	-	9,9,19	0.24	0	8,8,18	0.24	0
6	HEX	A	317	-	5,5,5	0.18	0	4,4,4	0.22	0
5	OLA	A	313	-	16,19,19	0.48	0	15,19,19	0.35	0
4	OLC	A	312	-	19,19,24	0.81	1 (5%)	19,19,25	1.81	4 (21%)
6	HEX	A	316	-	5,5,5	0.20	0	4,4,4	0.15	0
7	SO4	A	321	-	4,4,4	0.27	0	6,6,6	0.12	0
2	RET	A	301	1	20,20,21	3.57	7 (35%)	27,27,28	1.37	4 (14%)

Mol	Type	Chain	Res	Link	Bond lengths			Bond angles		
					Counts	RMSZ	# Z  > 2	Counts	RMSZ	# Z  > 2
3	LFA	A	305	-	17,17,19	0.20	0	16,16,18	0.16	0
3	LFA	A	306	-	6,6,19	0.10	0	5,5,18	0.12	0
3	LFA	A	311	-	10,10,19	0.16	0	9,9,18	0.19	0
3	LFA	A	310	-	8,8,19	0.16	0	7,7,18	0.23	0
5	OLA	A	315	-	11,14,19	0.20	0	10,14,19	0.28	0
5	OLA	A	314	-	15,18,19	0.46	0	14,18,19	0.30	0
3	LFA	A	309	-	10,10,19	0.41	0	9,9,18	0.28	0
6	HEX	A	318	-	3,3,5	0.25	0	2,2,4	0.44	0
7	SO4	A	320	-	4,4,4	0.50	0	6,6,6	0.56	0
3	LFA	A	303	-	12,12,19	0.31	0	11,11,18	0.16	0
3	LFA	A	302	-	17,17,19	0.19	0	16,16,18	0.11	0
6	HEX	A	319	-	5,5,5	0.13	0	4,4,4	0.14	0
3	LFA	A	307	-	5,5,19	0.33	0	4,4,18	0.20	0

In the following table, the Chirals column lists the number of chiral outliers, the number of chiral centers analysed, the number of these observed in the model and the number defined in the Chemical Component Dictionary. Similar counts are reported in the Torsion and Rings columns. '-' means no outliers of that kind were identified.

Mol	Type	Chain	Res	Link	Chirals	Torsions	Rings
3	LFA	A	304	-	-	7/17/17/17	-
3	LFA	A	308	-	-	3/7/7/17	-
6	HEX	A	317	-	-	2/3/3/3	-
5	OLA	A	313	-	-	3/15/17/17	-
4	OLC	A	312	-	-	9/18/18/24	-
6	HEX	A	316	-	-	0/3/3/3	-
2	RET	A	301	1	-	2/13/30/31	0/1/1/1
3	LFA	A	305	-	-	9/15/15/17	-
3	LFA	A	306	-	-	2/4/4/17	-
3	LFA	A	311	-	-	4/8/8/17	-
3	LFA	A	310	-	-	2/6/6/17	-
5	OLA	A	315	-	-	5/10/12/17	-
5	OLA	A	314	-	-	6/14/16/17	-
3	LFA	A	309	-	-	6/8/8/17	-
6	HEX	A	318	-	-	0/1/1/3	-
3	LFA	A	303	-	-	5/10/10/17	-
3	LFA	A	302	-	-	8/15/15/17	-
6	HEX	A	319	-	-	2/3/3/3	-
3	LFA	A	307	-	-	2/3/3/17	-

The worst 5 of 8 bond length outliers are listed below:

Mol	Chain	Res	Type	Atoms	Z	Observed(Å)	Ideal(Å)
2	A	301	RET	C14-C13	12.84	1.43	1.33
2	A	301	RET	C2-C3	-4.75	1.40	1.52
2	A	301	RET	C15-C14	-4.10	1.34	1.49
2	A	301	RET	C10-C9	3.58	1.40	1.35
2	A	301	RET	C12-C13	-3.48	1.38	1.45

The worst 5 of 8 bond angle outliers are listed below:

Mol	Chain	Res	Type	Atoms	Z	Observed(°)	Ideal(°)
4	A	312	OLC	C21-O20-C1	-4.83	101.31	116.92
4	A	312	OLC	O20-C1-O19	-4.42	112.43	123.59
2	A	301	RET	C12-C13-C14	-3.28	108.38	118.80
4	A	312	OLC	O20-C21-C22	3.04	117.75	108.30
2	A	301	RET	C19-C9-C10	-2.88	118.88	122.92

There are no chirality outliers.

5 of 77 torsion outliers are listed below:

Mol	Chain	Res	Type	Atoms
2	A	301	RET	C20-C13-C14-C15
4	A	312	OLC	C22-C21-O20-C1
5	A	314	OLA	C2-C3-C4-C5
3	A	303	LFA	C9-C10-C11-C12
5	A	314	OLA	C11-C12-C13-C14

There are no ring outliers.

10 monomers are involved in 58 short contacts:

Mol	Chain	Res	Type	Clashes	Symm-Clashes
3	A	304	LFA	7	0
3	A	308	LFA	8	0
6	A	317	HEX	1	0
4	A	312	OLC	11	0
2	A	301	RET	3	0
3	A	305	LFA	1	0
5	A	315	OLA	3	0
5	A	314	OLA	3	0
3	A	309	LFA	20	0
3	A	302	LFA	1	0

The following is a two-dimensional graphical depiction of Mogul quality analysis of bond lengths,

bond angles, torsion angles, and ring geometry for all instances of the Ligand of Interest. In addition, ligands with molecular weight > 250 and outliers as shown on the validation Tables will also be included. For torsion angles, if less than 5% of the Mogul distribution of torsion angles is within 10 degrees of the torsion angle in question, then that torsion angle is considered an outlier. Any bond that is central to one or more torsion angles identified as an outlier by Mogul will be highlighted in the graph. For rings, the root-mean-square deviation (RMSD) between the ring in question and similar rings identified by Mogul is calculated over all ring torsion angles. If the average RMSD is greater than 60 degrees and the minimal RMSD between the ring in question and any Mogul-identified rings is also greater than 60 degrees, then that ring is considered an outlier. The outliers are highlighted in purple. The color gray indicates Mogul did not find sufficient equivalents in the CSD to analyse the geometry.

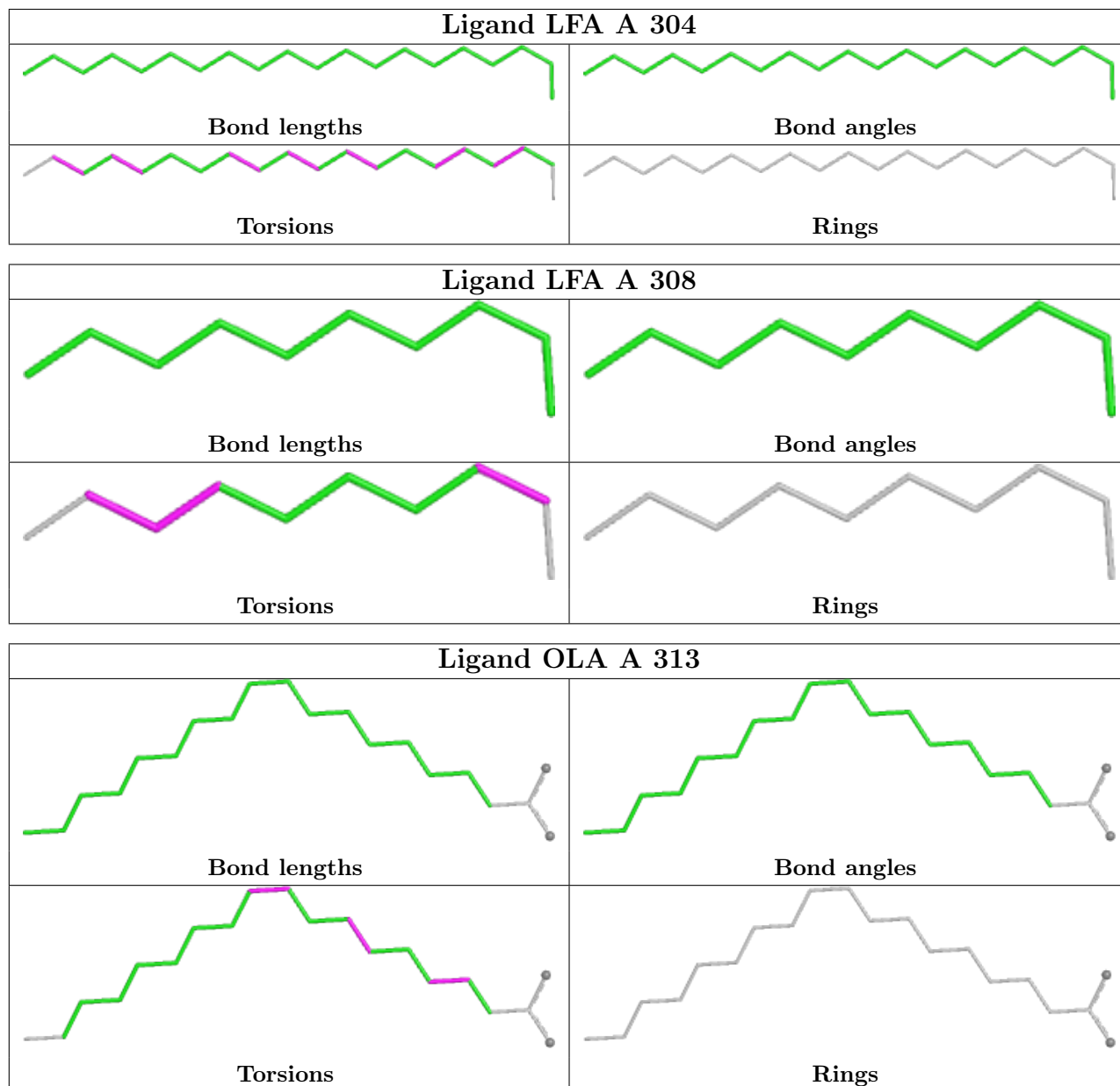

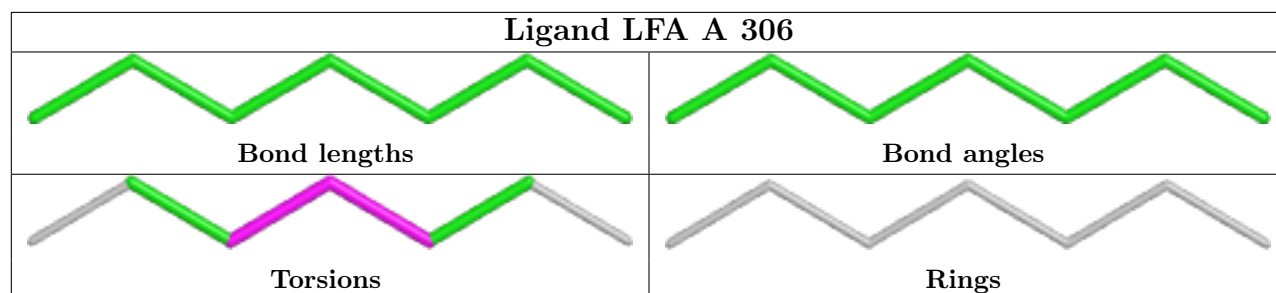
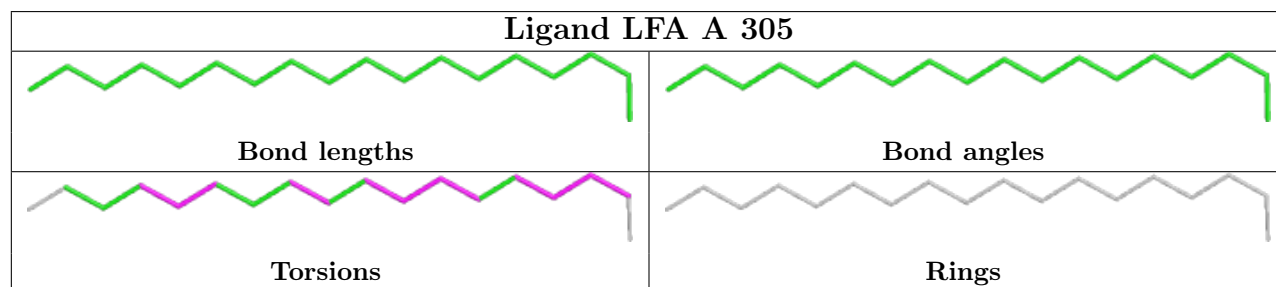
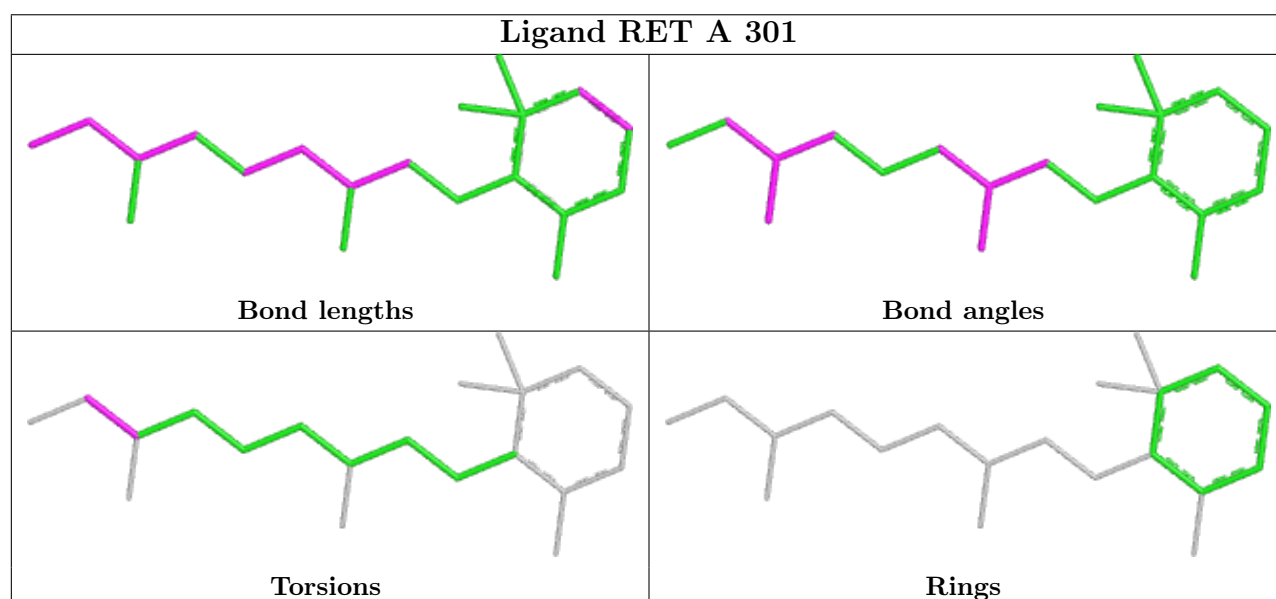
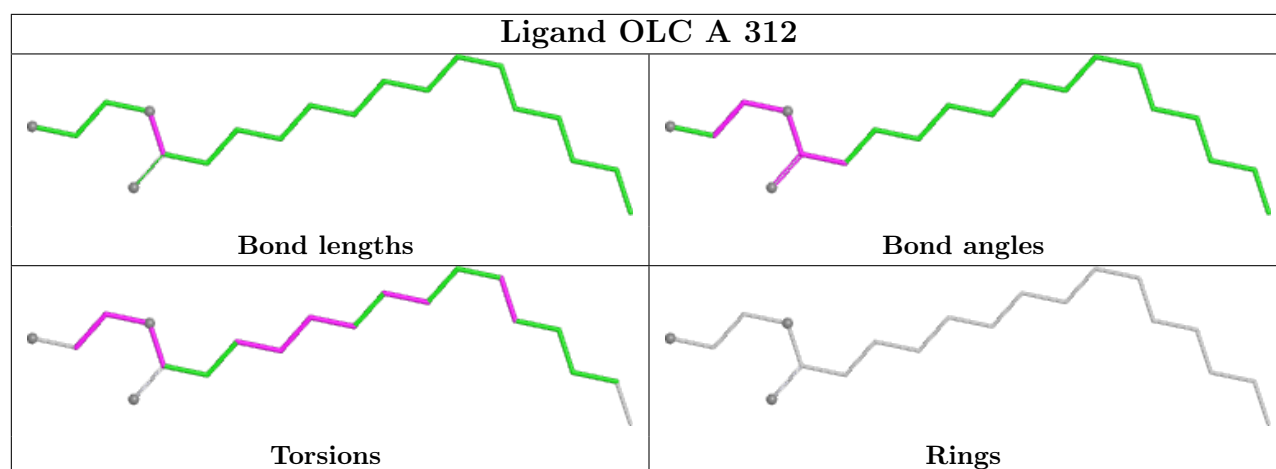

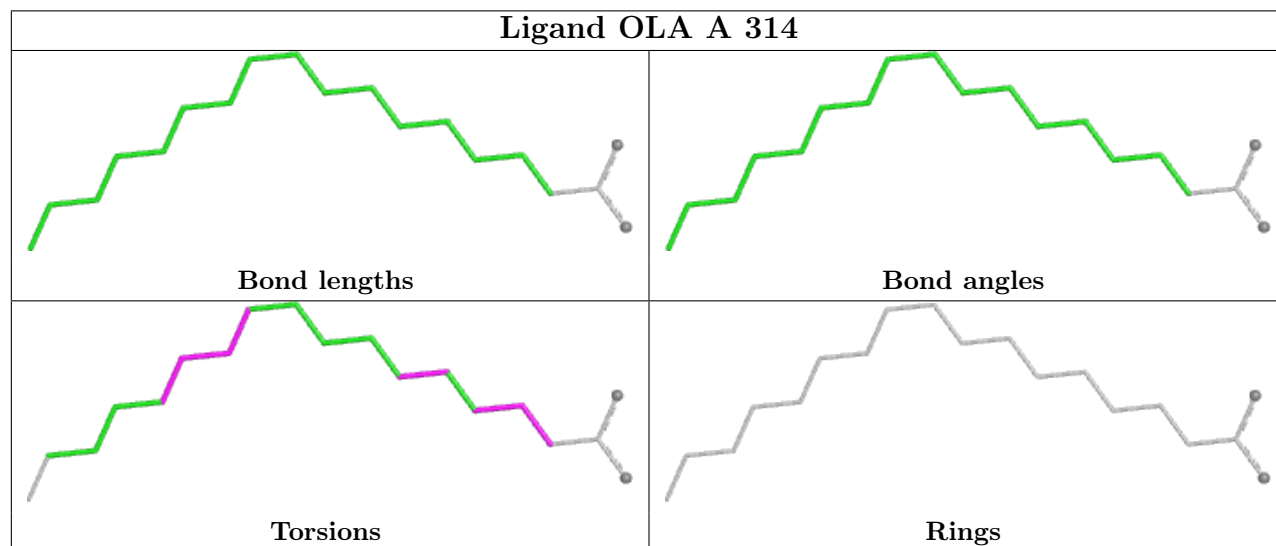
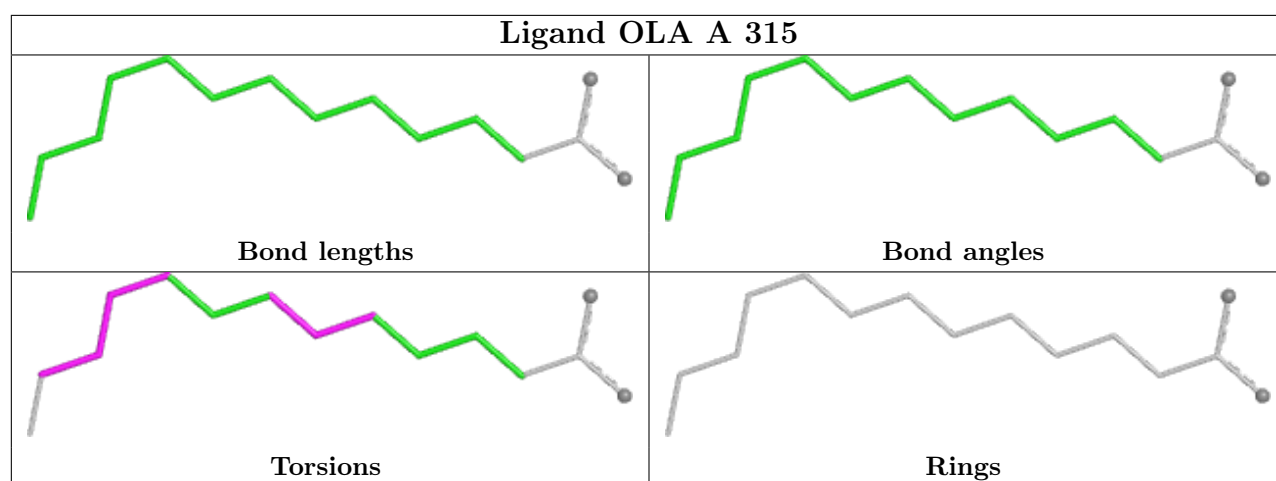
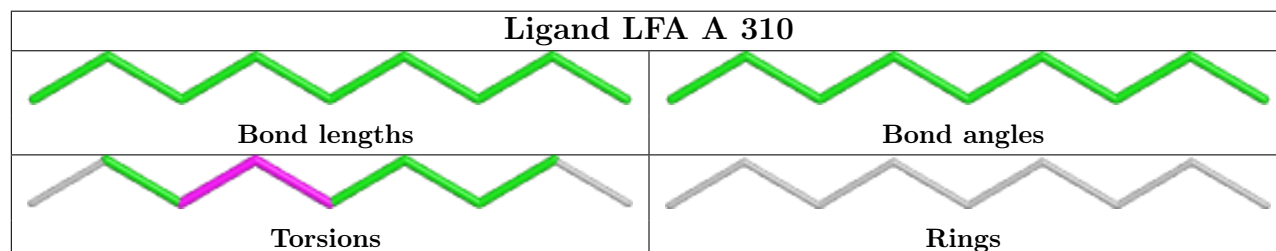
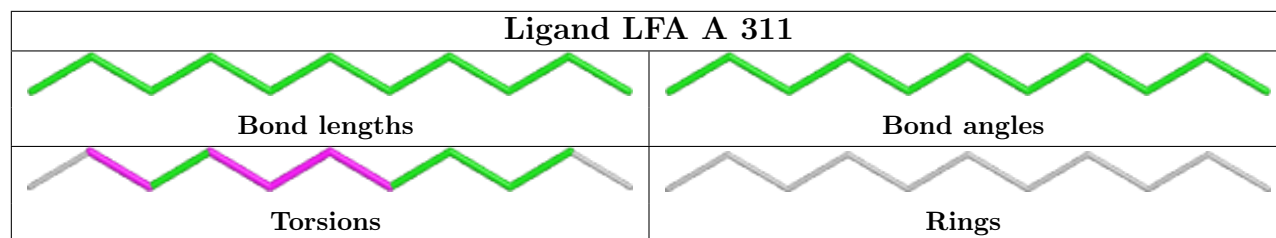

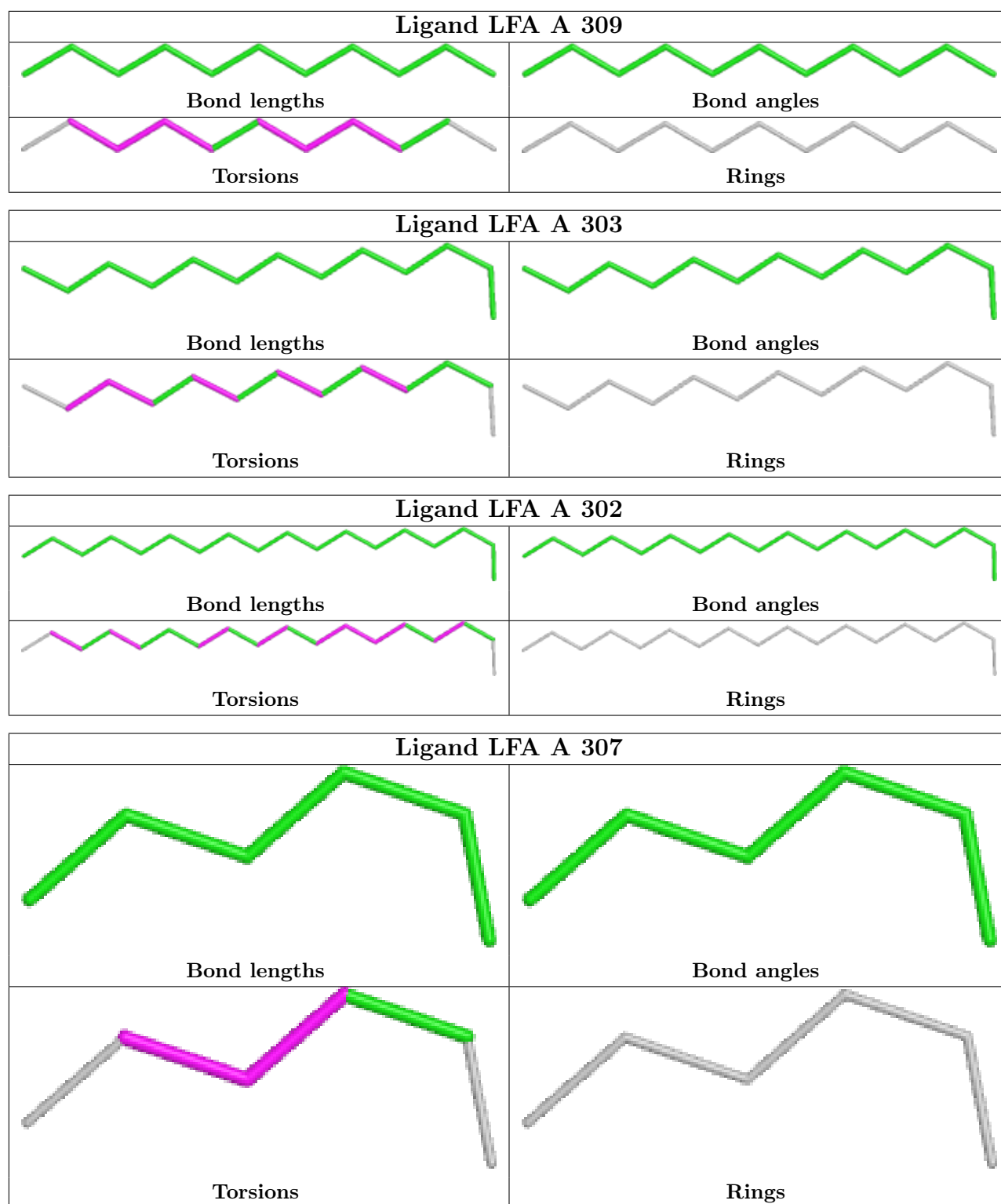

## 5.7 Other polymers [\(i\)](#)

There are no such residues in this entry.



## 5.8 Polymer linkage issues

There are no chain breaks in this entry.

## 6 Fit of model and data [i](#)

### 6.1 Protein, DNA and RNA chains [i](#)

In the following table, the column labelled '#RSRZ > 2' contains the number (and percentage) of RSRZ outliers, followed by percent RSRZ outliers for the chain as percentile scores relative to all X-ray entries and entries of similar resolution. The OWAB column contains the minimum, median, 95<sup>th</sup> percentile and maximum values of the occupancy-weighted average B-factor per residue. The column labelled 'Q < 0.9' lists the number of (and percentage) of residues with an average occupancy less than 0.9.

Mol	Chain	Analysed	<RSRZ>	#RSRZ>2	OWAB(Å <sup>2</sup> )	Q<0.9
1	A	228/269 (84%)	0.39	18 (7%) <b>12</b> <b>12</b>	16, 22, 43, 70	0

The worst 5 of 18 RSRZ outliers are listed below:

Mol	Chain	Res	Type	RSRZ
1	A	73	GLY	6.7
1	A	5[A]	THR	5.5
1	A	6	GLY	5.5
1	A	70	PRO	4.8
1	A	72	GLY	4.4

### 6.2 Non-standard residues in protein, DNA, RNA chains [i](#)

There are no non-standard protein/DNA/RNA residues in this entry.

### 6.3 Carbohydrates [i](#)

There are no monosaccharides in this entry.

### 6.4 Ligands [i](#)

In the following table, the Atoms column lists the number of modelled atoms in the group and the number defined in the chemical component dictionary. The B-factors column lists the minimum, median, 95<sup>th</sup> percentile and maximum values of B factors of atoms in the group. The column labelled 'Q < 0.9' lists the number of atoms with occupancy less than 0.9.

Mol	Type	Chain	Res	Atoms	RSCC	RSR	B-factors(Å <sup>2</sup> )	Q<0.9
3	LFA	A	310	9/20	0.49	0.24	57,61,64,69	0
6	HEX	A	316	6/6	0.55	0.22	59,62,65,66	0

*Continued on next page...*

*Continued from previous page...*

Mol	Type	Chain	Res	Atoms	RSCC	RSR	B-factors(Å <sup>2</sup> )	Q<0.9
8	AR	A	366	1/1	0.58	0.46	26,26,26,26	1
4	OLC	A	312	20/25	0.59	0.29	32,49,58,62	20
3	LFA	A	303	13/20	0.60	0.16	48,60,66,66	0
5	OLA	A	315	15/20	0.60	0.28	45,73,81,82	0
3	LFA	A	305	18/20	0.64	0.19	36,54,68,68	0
8	AR	A	326	1/1	0.66	0.79	21,21,21,21	1
3	LFA	A	308	10/20	0.66	0.24	47,51,72,74	0
5	OLA	A	314	19/20	0.72	0.21	36,54,87,88	0
6	HEX	A	318	4/6	0.76	0.15	50,52,53,54	0
8	AR	A	367	1/1	0.76	0.82	24,24,24,24	1
3	LFA	A	306	7/20	0.77	0.17	59,62,72,76	0
3	LFA	A	311	11/20	0.80	0.23	50,57,66,67	0
8	AR	A	359	1/1	0.81	0.18	24,24,24,24	1
7	SO4	A	321	5/5	0.81	0.39	59,68,77,84	0
3	LFA	A	304	20/20	0.81	0.19	43,50,66,67	0
3	LFA	A	307	6/20	0.83	0.30	23,45,57,68	0
6	HEX	A	319	6/6	0.84	0.17	49,52,56,59	0
8	AR	A	365	1/1	0.84	0.17	19,19,19,19	1
2	RET	A	301	20/21	0.85	0.12	17,19,25,25	0
8	AR	A	336	1/1	0.85	0.42	20,20,20,20	1
5	OLA	A	313	20/20	0.86	0.15	25,37,63,64	0
3	LFA	A	309	11/20	0.86	0.36	20,22,25,25	11
6	HEX	A	317	6/6	0.86	0.18	44,45,49,50	0
3	LFA	A	302	18/20	0.87	0.16	35,42,56,59	18
8	AR	A	340	1/1	0.87	0.48	19,19,19,19	1
8	AR	A	364	1/1	0.88	0.82	19,19,19,19	1
8	AR	A	363	1/1	0.88	0.41	20,20,20,20	1
8	AR	A	357	1/1	0.89	0.52	19,19,19,19	1
8	AR	A	360	1/1	0.90	0.28	21,21,21,21	1
8	AR	A	325	1/1	0.90	0.45	21,21,21,21	1
8	AR	A	355	1/1	0.91	0.29	18,18,18,18	1
8	AR	A	356	1/1	0.91	0.47	27,27,27,27	1
8	AR	A	330	1/1	0.91	0.45	22,22,22,22	1
8	AR	A	353	1/1	0.91	0.18	26,26,26,26	1
8	AR	A	354	1/1	0.91	0.29	20,20,20,20	1
7	SO4	A	320	5/5	0.92	0.13	24,25,26,28	5
8	AR	A	368	1/1	0.92	0.63	23,23,23,23	1
8	AR	A	342	1/1	0.94	0.17	24,24,24,24	1
8	AR	A	344	1/1	0.94	0.24	21,21,21,21	1
8	AR	A	346	1/1	0.94	0.37	18,18,18,18	1
8	AR	A	339	1/1	0.94	0.17	22,22,22,22	1
8	AR	A	328	1/1	0.94	0.34	20,20,20,20	1

*Continued on next page...*

*Continued from previous page...*

Mol	Type	Chain	Res	Atoms	RSCC	RSR	B-factors( $\text{\AA}^2$ )	Q<0.9
8	AR	A	361	1/1	0.94	0.16	31,31,31,31	1
8	AR	A	347	1/1	0.95	0.36	22,22,22,22	1
8	AR	A	329	1/1	0.96	0.12	24,24,24,24	1
8	AR	A	341	1/1	0.96	0.43	19,19,19,19	1
8	AR	A	350	1/1	0.96	0.26	22,22,22,22	1
8	AR	A	352	1/1	0.96	0.19	18,18,18,18	1
8	AR	A	337	1/1	0.96	0.39	24,24,24,24	1
8	AR	A	335	1/1	0.96	0.91	18,18,18,18	1
8	AR	A	358	1/1	0.97	0.39	24,24,24,24	1
8	AR	A	333	1/1	0.97	0.16	19,19,19,19	1
8	AR	A	332	1/1	0.98	0.12	23,23,23,23	1
8	AR	A	362	1/1	0.98	0.20	20,20,20,20	1
8	AR	A	327	1/1	0.98	0.30	19,19,19,19	1
8	AR	A	348	1/1	0.98	0.24	26,26,26,26	1
8	AR	A	338	1/1	0.98	0.67	24,24,24,24	1
8	AR	A	351	1/1	0.98	0.09	23,23,23,23	1
8	AR	A	343	1/1	0.98	0.26	22,22,22,22	1
8	AR	A	331	1/1	0.98	0.26	26,26,26,26	1
8	AR	A	349	1/1	0.99	0.10	22,22,22,22	1
8	AR	A	345	1/1	0.99	0.06	25,25,25,25	1
8	AR	A	322	1/1	0.99	0.14	18,18,18,18	1
8	AR	A	334	1/1	0.99	0.52	19,19,19,19	1
8	AR	A	323	1/1	0.99	0.66	19,19,19,19	1
8	AR	A	324	1/1	1.00	0.28	21,21,21,21	1

The following is a graphical depiction of the model fit to experimental electron density of all instances of the Ligand of Interest. In addition, ligands with molecular weight > 250 and outliers as shown on the geometry validation Tables will also be included. Each fit is shown from different orientation to approximate a three-dimensional view.

**Electron density around LFA A 310:**

$2mF_o-DF_c$  (at 0.7 rmsd) in gray  
 $mF_o-DF_c$  (at 3 rmsd) in purple (negative)  
and green (positive)

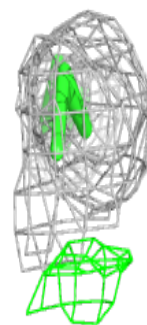
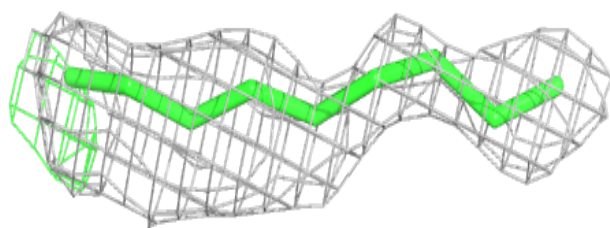
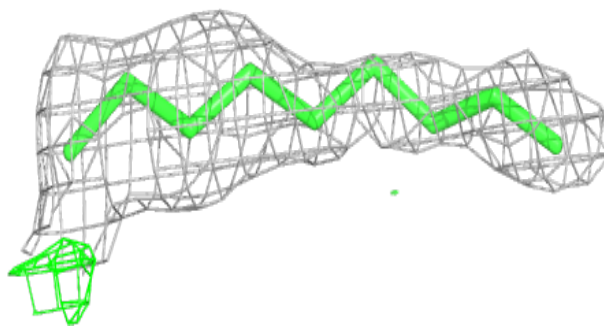

**Electron density around AR A 366:**

$2mF_o-DF_c$  (at 0.7 rmsd) in gray  
 $mF_o-DF_c$  (at 3 rmsd) in purple (negative)  
and green (positive)

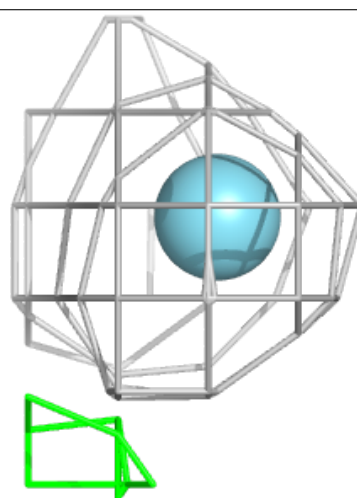
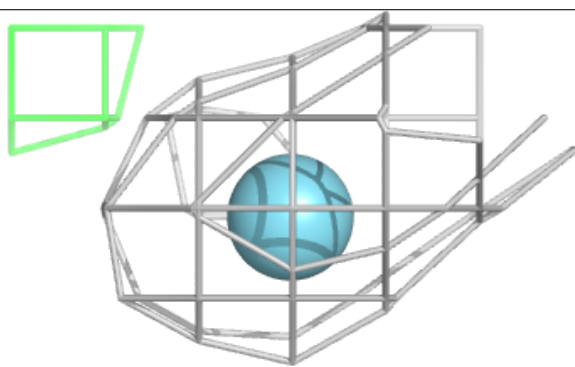
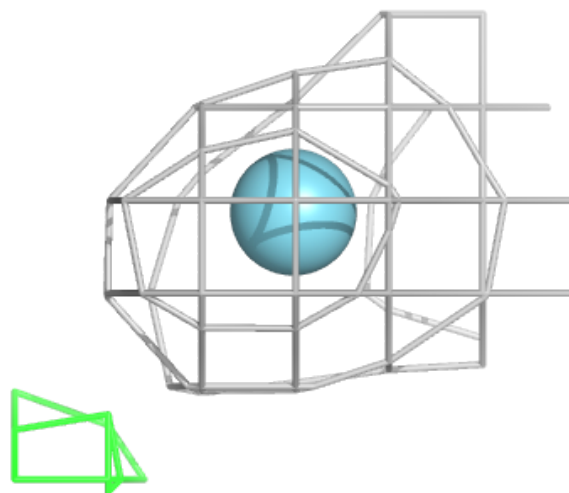

**Electron density around OLC A 312:**

$2mF_o-DF_c$  (at 0.7 rmsd) in gray  
 $mF_o-DF_c$  (at 3 rmsd) in purple (negative)  
and green (positive)

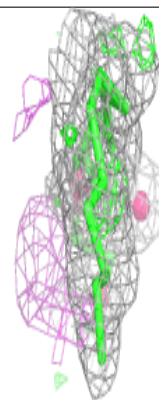
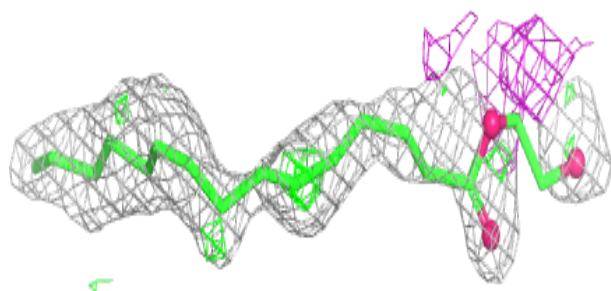
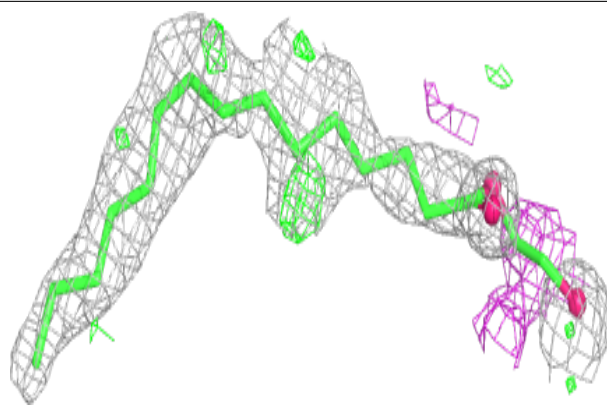
**Electron density around LFA A 303:**

$2mF_o-DF_c$  (at 0.7 rmsd) in gray  
 $mF_o-DF_c$  (at 3 rmsd) in purple (negative)  
and green (positive)

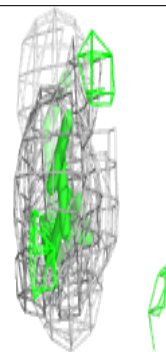
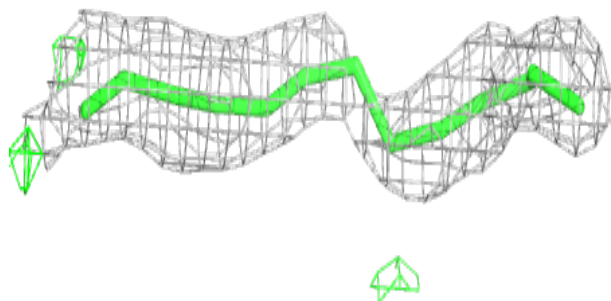
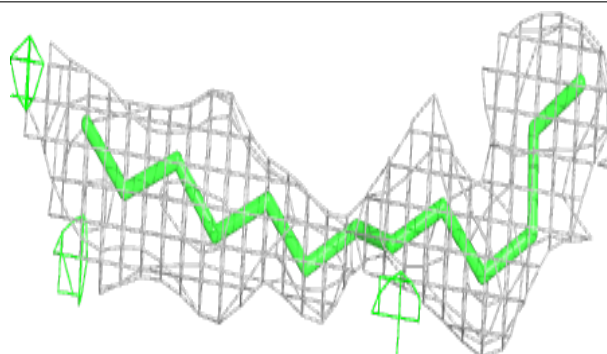

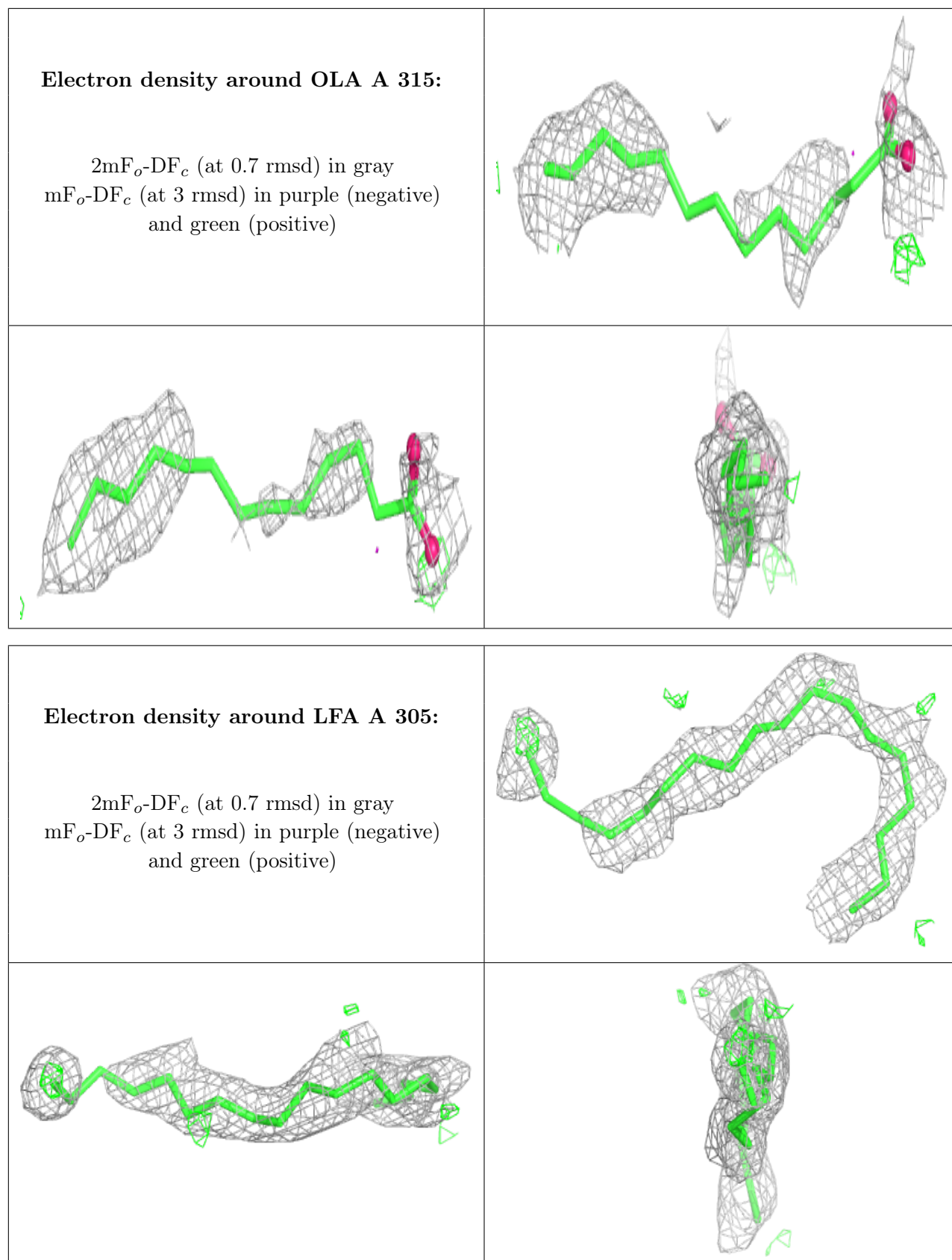



**Electron density around AR A 326:**

$2mF_o-DF_c$  (at 0.7 rmsd) in gray  
 $mF_o-DF_c$  (at 3 rmsd) in purple (negative)  
and green (positive)

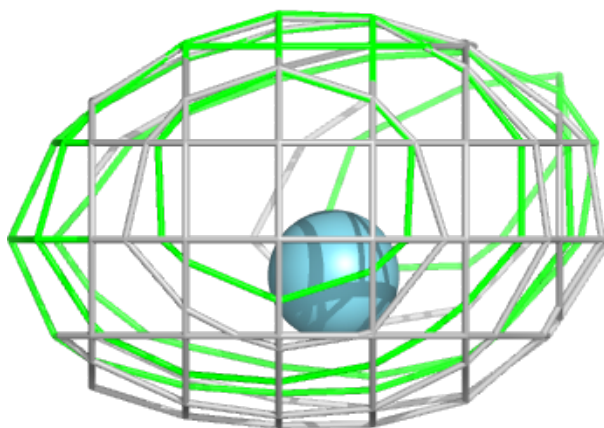
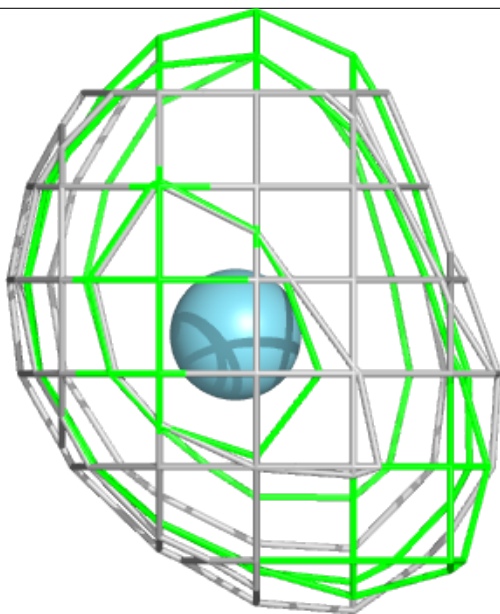
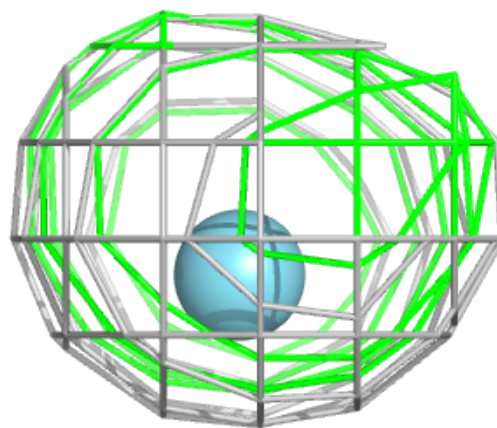

**Electron density around LFA A 308:**

$2mF_o-DF_c$  (at 0.7 rmsd) in gray  
 $mF_o-DF_c$  (at 3 rmsd) in purple (negative)  
and green (positive)

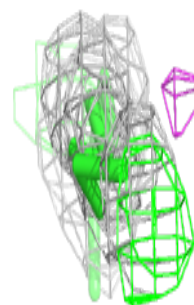
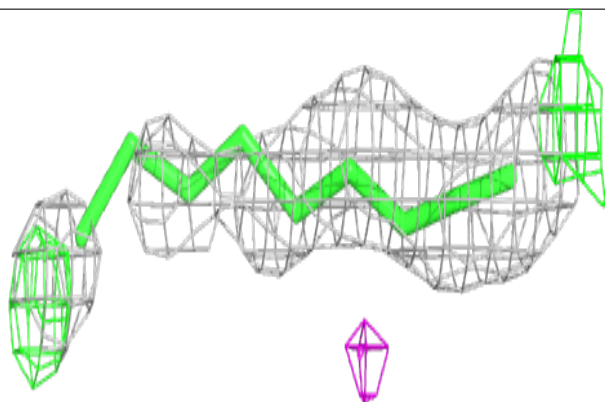
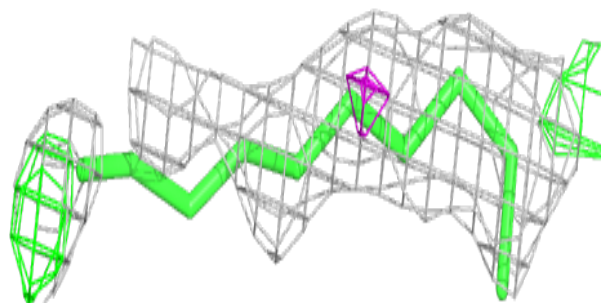
**Electron density around OLA A 314:**

$2mF_o-DF_c$  (at 0.7 rmsd) in gray  
 $mF_o-DF_c$  (at 3 rmsd) in purple (negative)  
and green (positive)

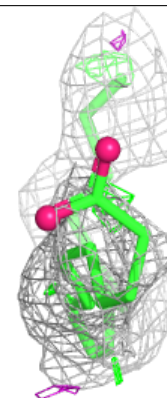
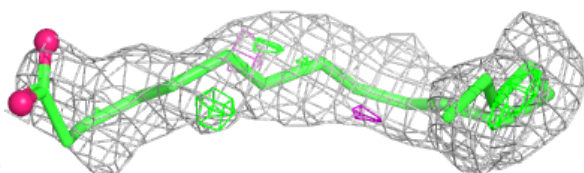
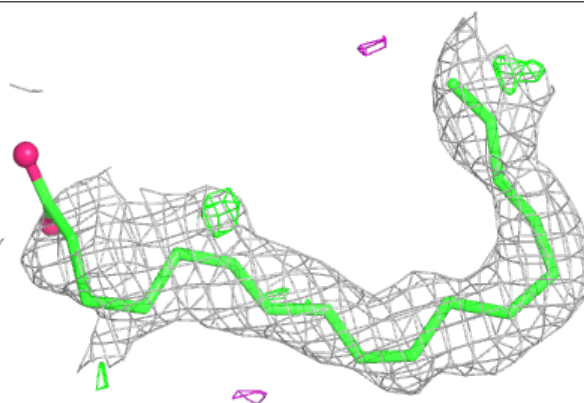

**Electron density around AR A 367:**

$2mF_o-DF_c$  (at 0.7 rmsd) in gray  
 $mF_o-DF_c$  (at 3 rmsd) in purple (negative)  
and green (positive)

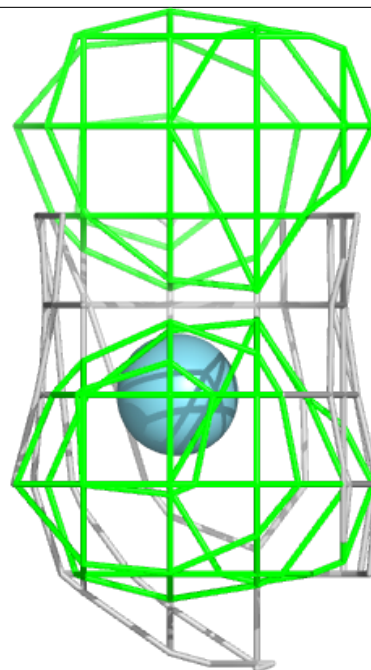
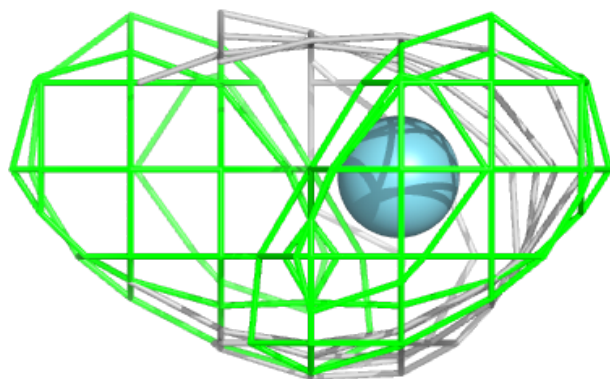
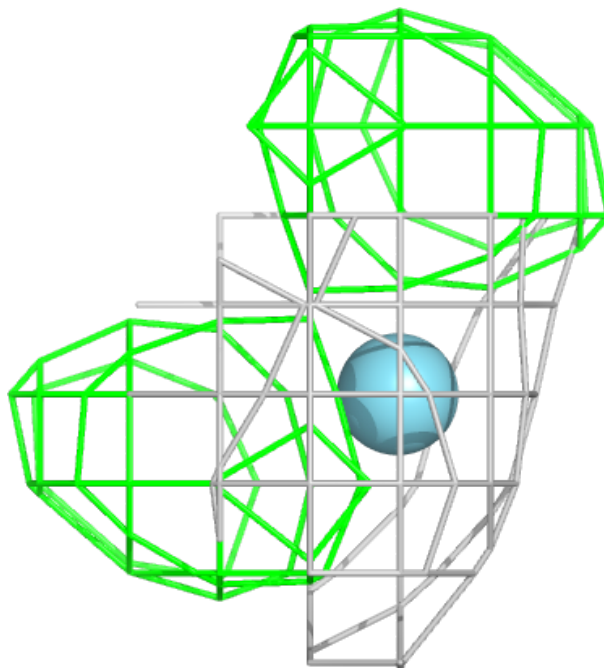

**Electron density around LFA A 306:**

$2mF_o-DF_c$  (at 0.7 rmsd) in gray  
 $mF_o-DF_c$  (at 3 rmsd) in purple (negative)  
and green (positive)

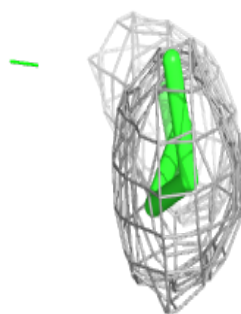
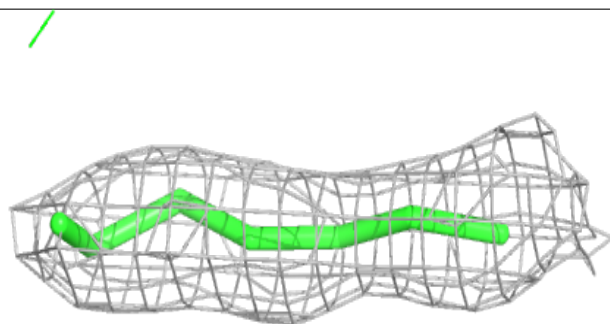
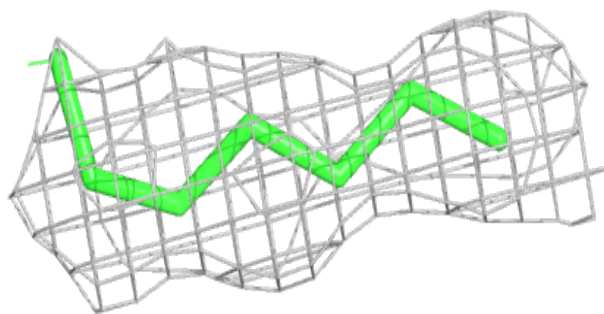
**Electron density around LFA A 311:**

$2mF_o-DF_c$  (at 0.7 rmsd) in gray  
 $mF_o-DF_c$  (at 3 rmsd) in purple (negative)  
and green (positive)

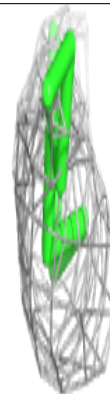
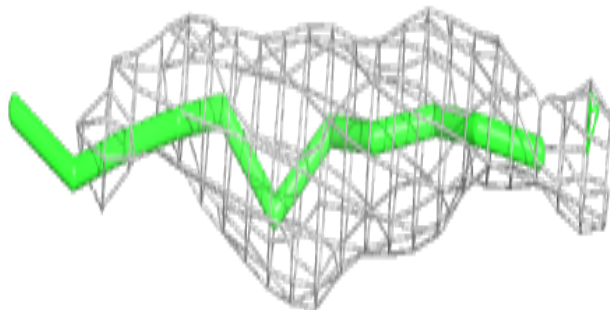
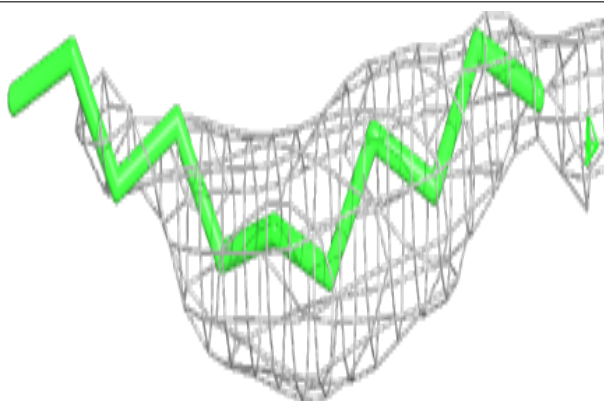

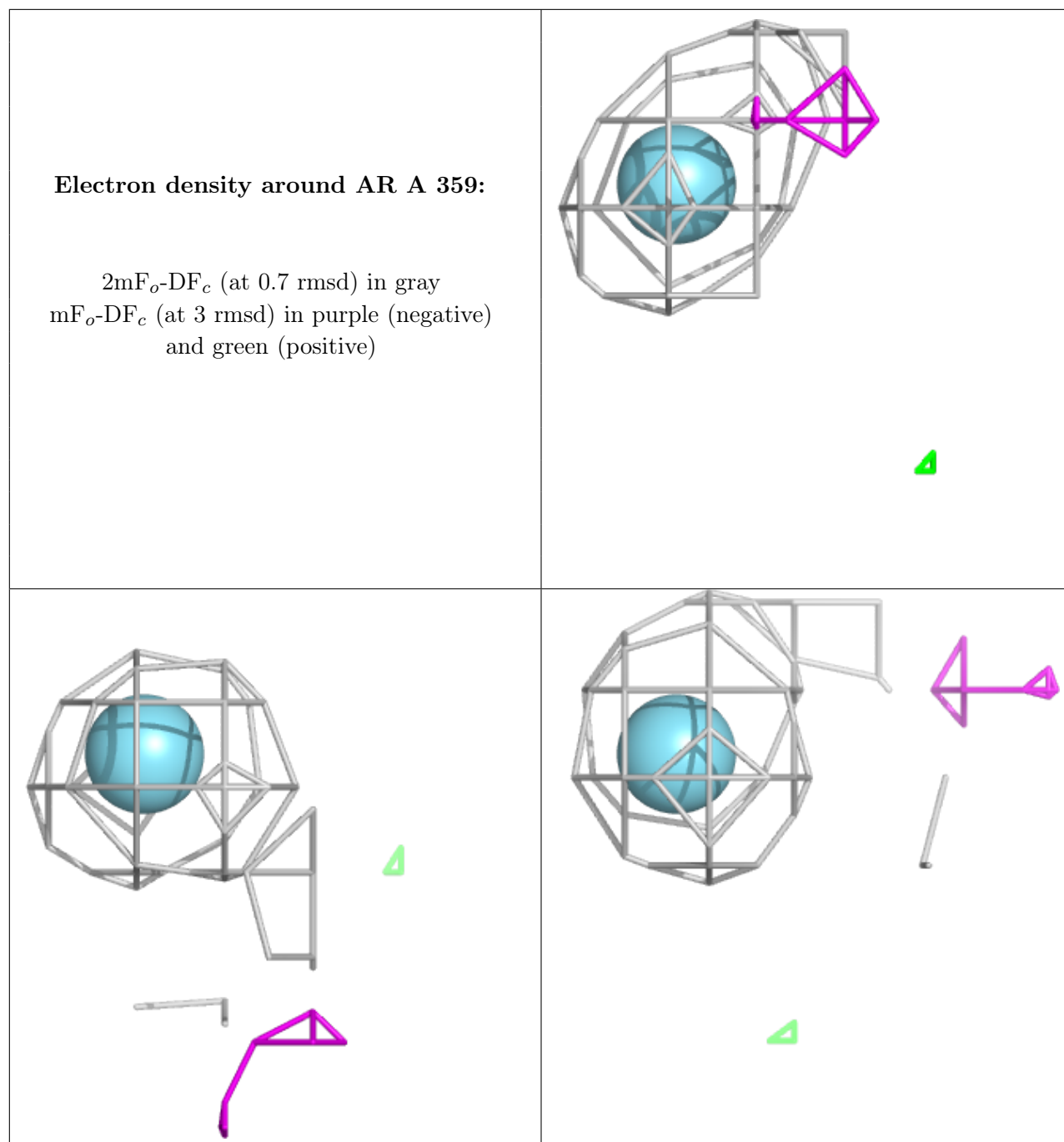



**Electron density around LFA A 304:**

$2mF_o-DF_c$  (at 0.7 rmsd) in gray  
 $mF_o-DF_c$  (at 3 rmsd) in purple (negative)  
and green (positive)

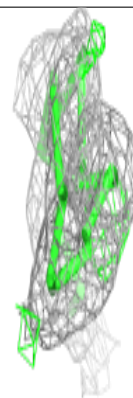
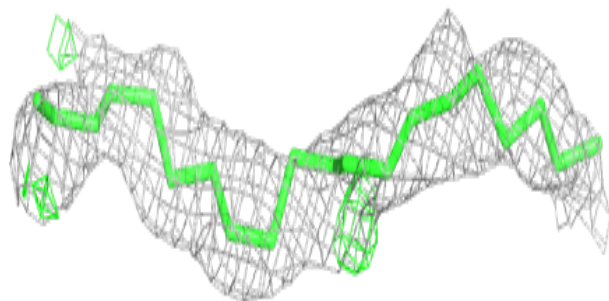
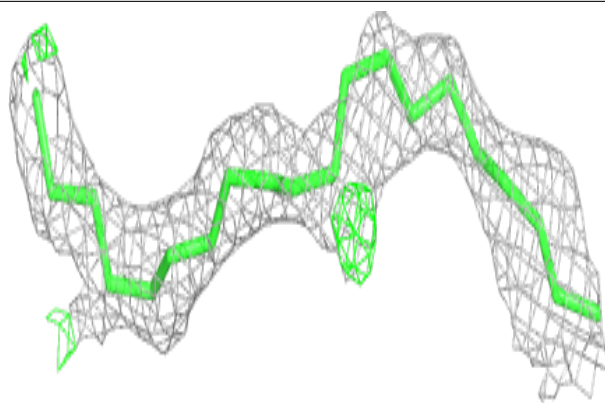
**Electron density around LFA A 307:**

$2mF_o-DF_c$  (at 0.7 rmsd) in gray  
 $mF_o-DF_c$  (at 3 rmsd) in purple (negative)  
and green (positive)

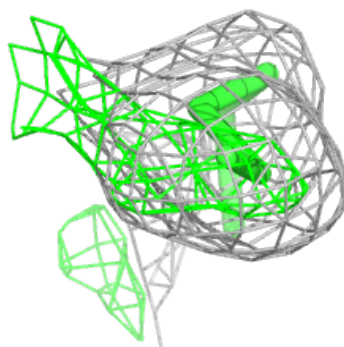
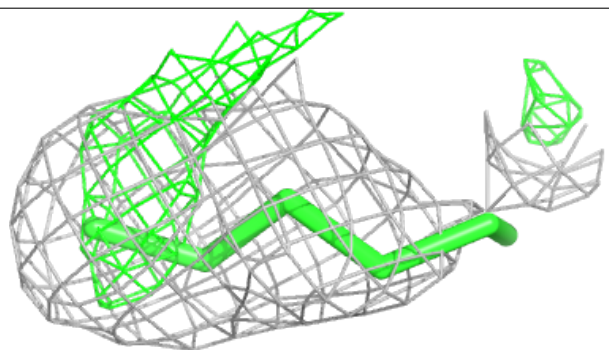
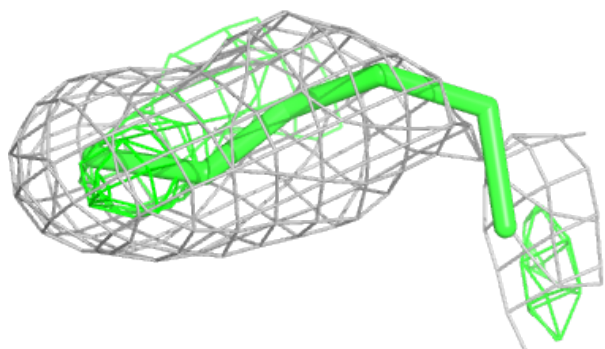

**Electron density around AR A 365:**

$2mF_o-DF_c$  (at 0.7 rmsd) in gray  
 $mF_o-DF_c$  (at 3 rmsd) in purple (negative)  
and green (positive)

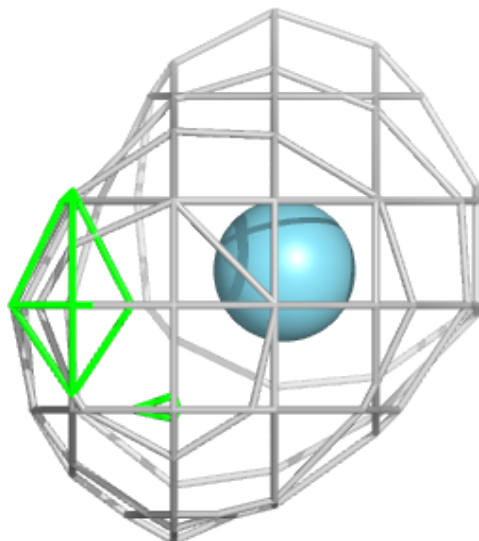
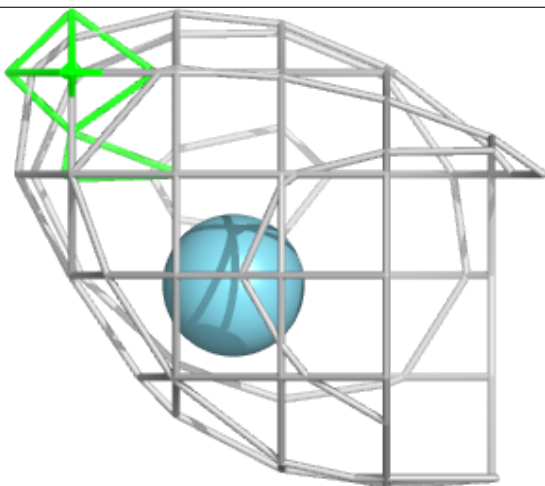
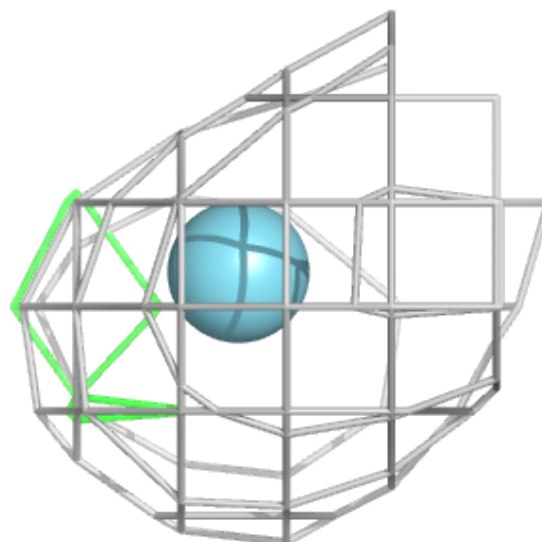

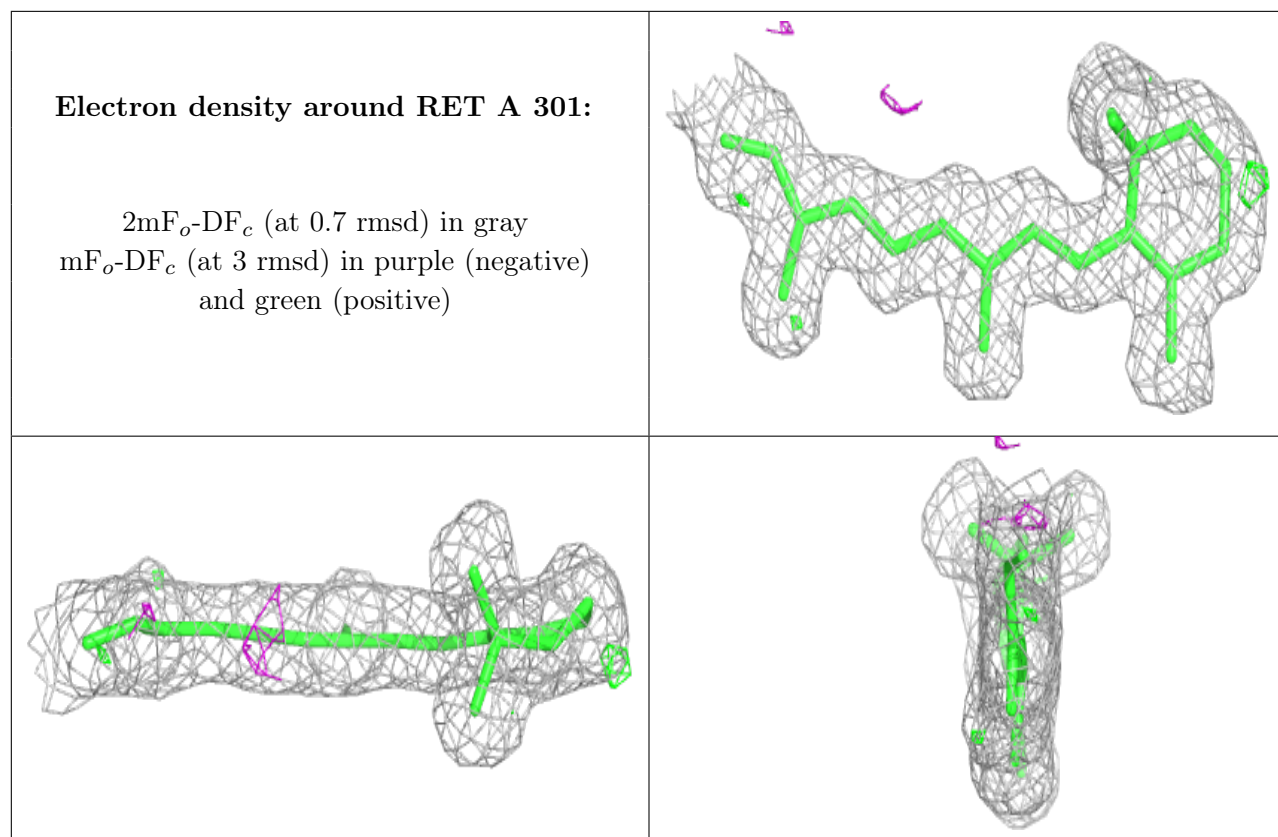



**Electron density around AR A 336:**

$2mF_o-DF_c$  (at 0.7 rmsd) in gray  
 $mF_o-DF_c$  (at 3 rmsd) in purple (negative)  
and green (positive)

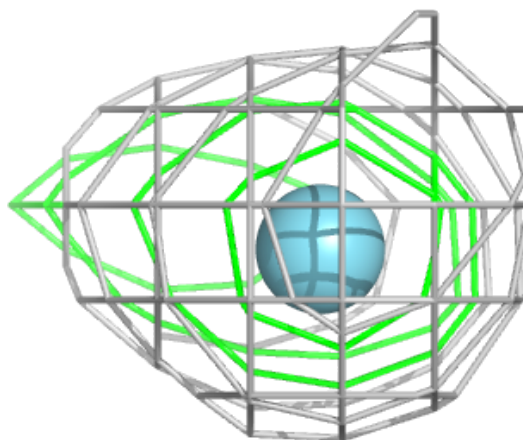
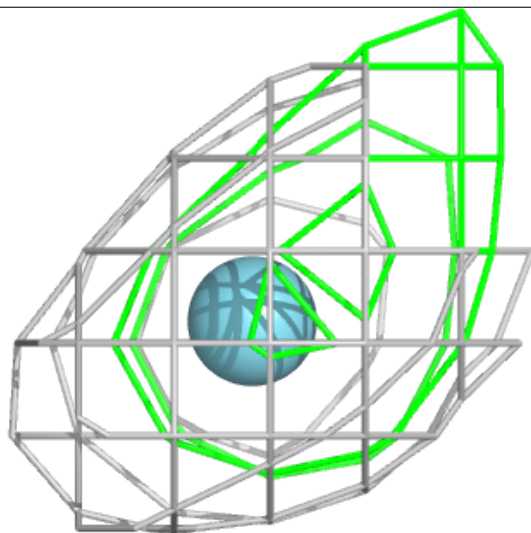
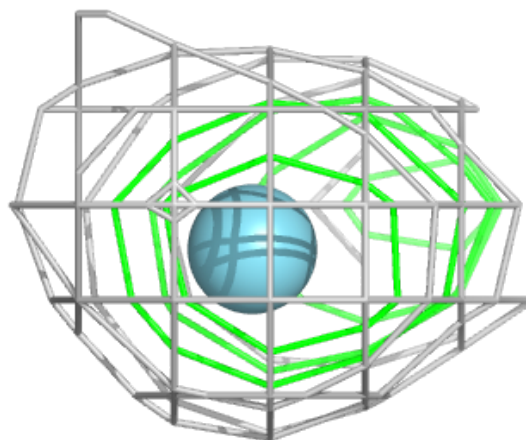

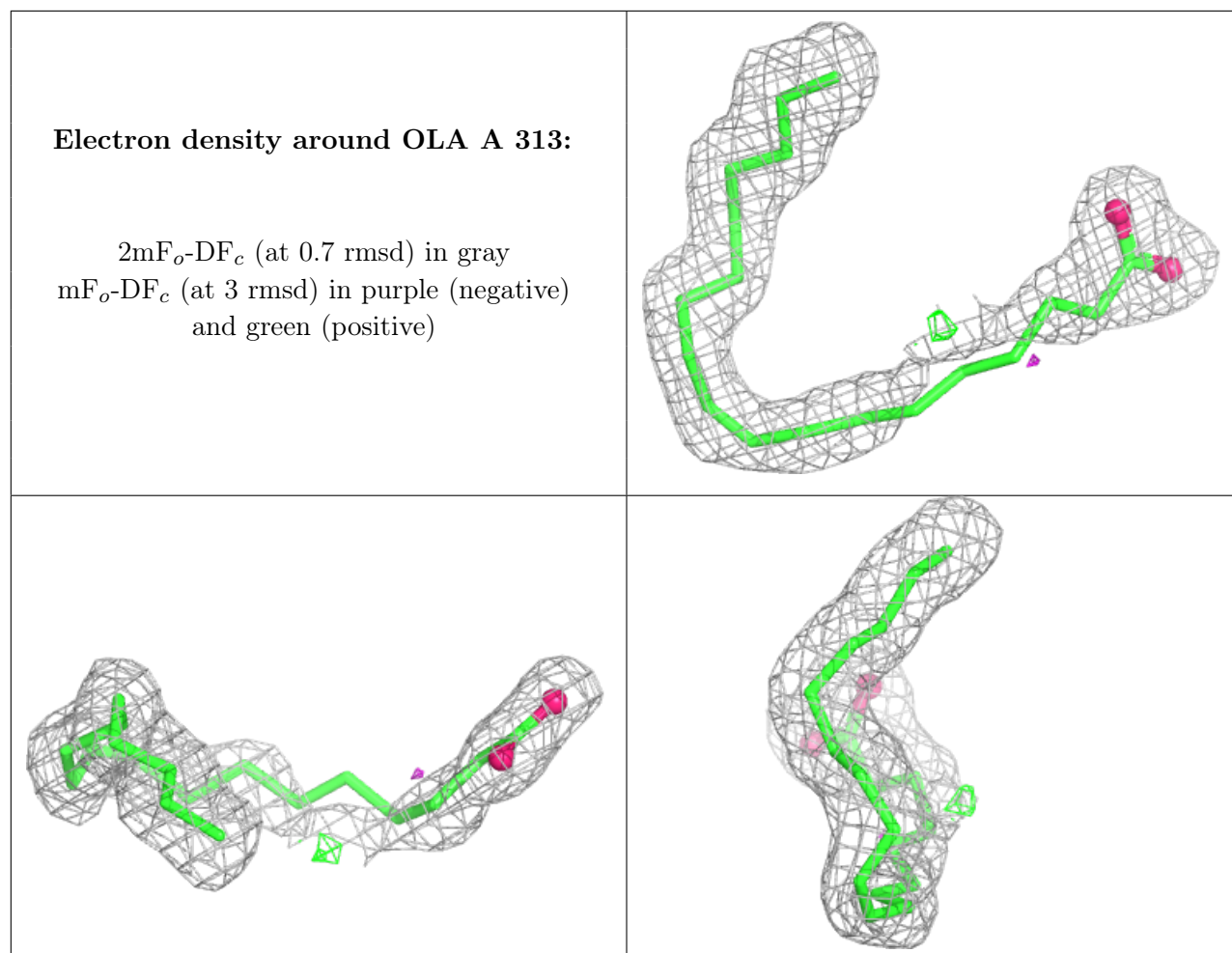

**Electron density around LFA A 309:**

$2mF_o-DF_c$  (at 0.7 rmsd) in gray  
 $mF_o-DF_c$  (at 3 rmsd) in purple (negative)  
and green (positive)

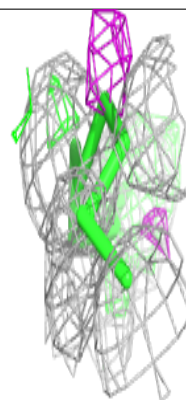
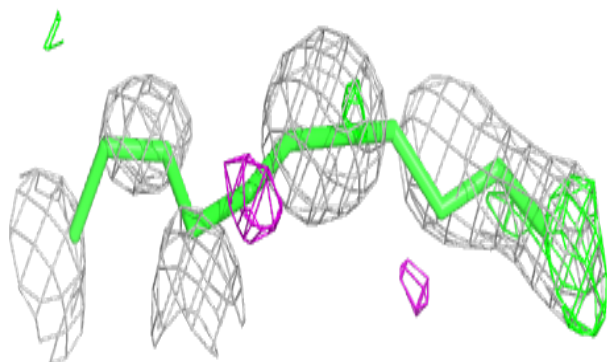
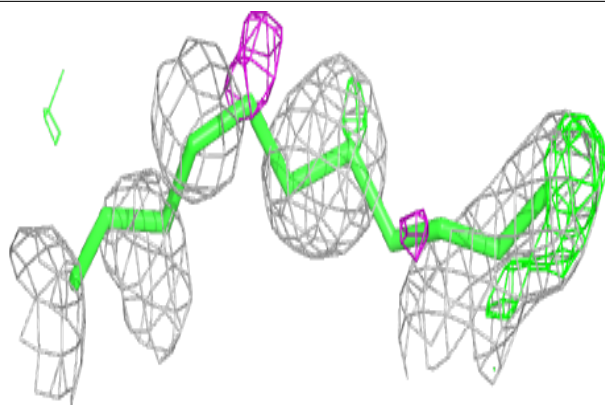
**Electron density around LFA A 302:**

$2mF_o-DF_c$  (at 0.7 rmsd) in gray  
 $mF_o-DF_c$  (at 3 rmsd) in purple (negative)  
and green (positive)

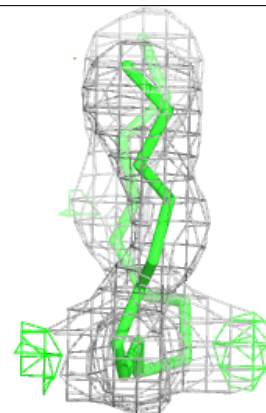
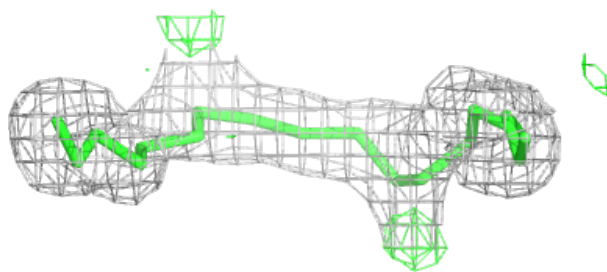
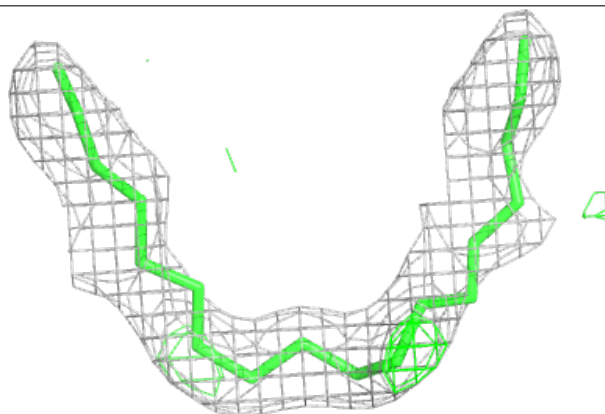

**Electron density around AR A 340:**

$2mF_o-DF_c$  (at 0.7 rmsd) in gray  
 $mF_o-DF_c$  (at 3 rmsd) in purple (negative)  
and green (positive)

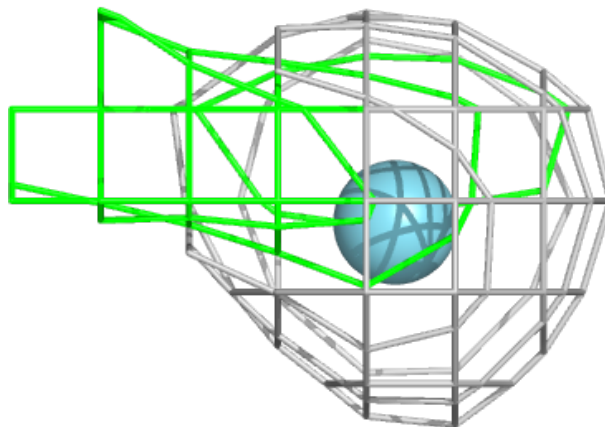
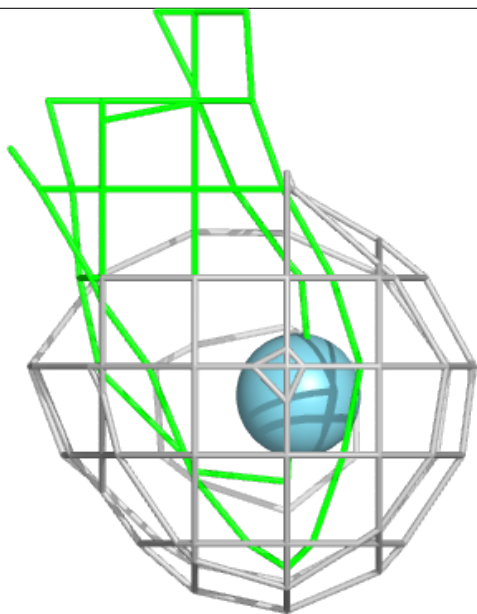
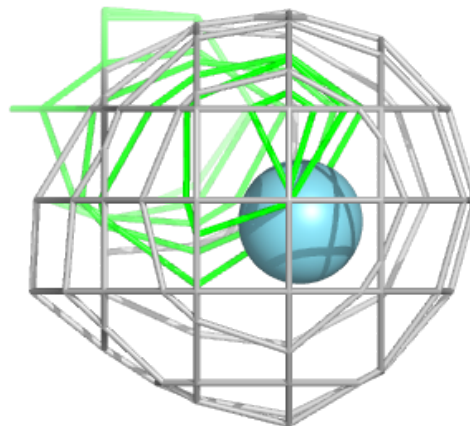

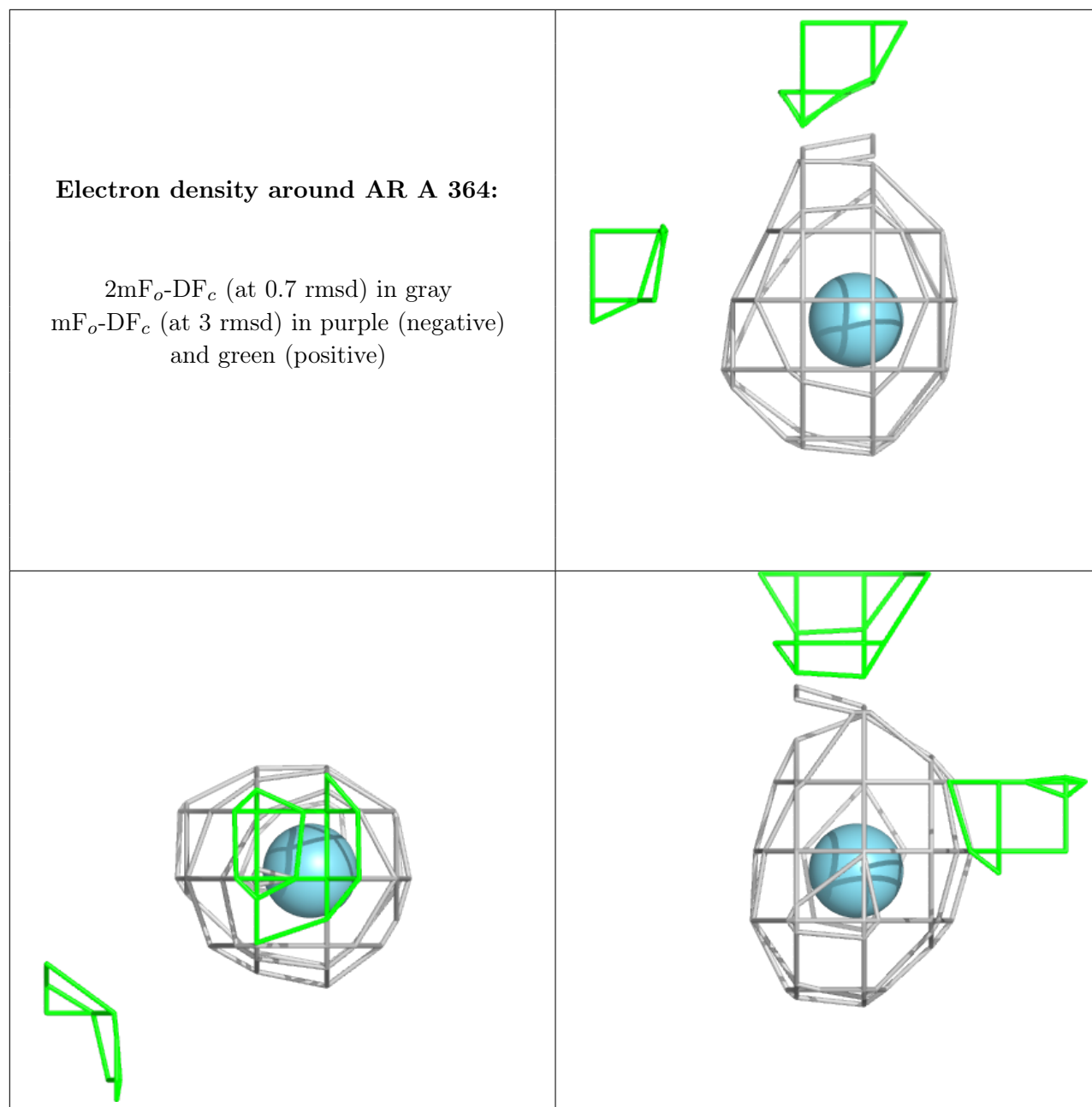

**Electron density around AR A 363:**

$2mF_o-DF_c$  (at 0.7 rmsd) in gray  
 $mF_o-DF_c$  (at 3 rmsd) in purple (negative)  
and green (positive)

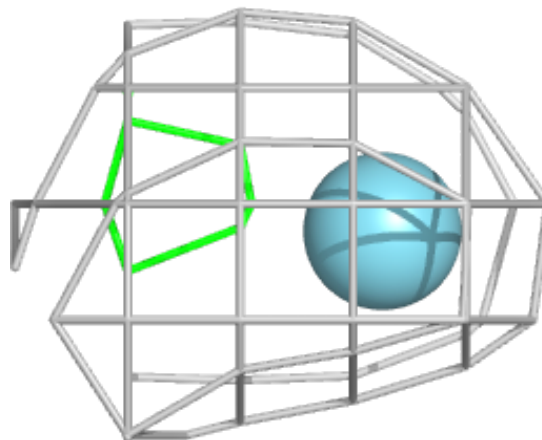
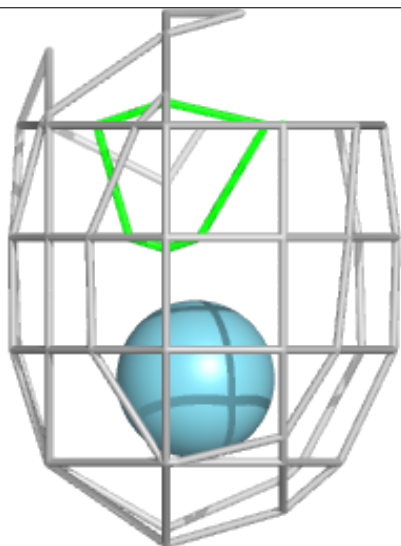
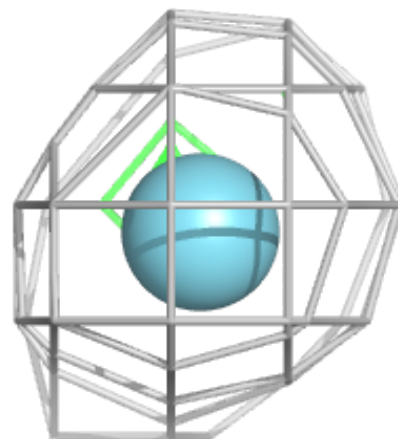

**Electron density around AR A 357:**

$2mF_o-DF_c$  (at 0.7 rmsd) in gray  
 $mF_o-DF_c$  (at 3 rmsd) in purple (negative)  
and green (positive)

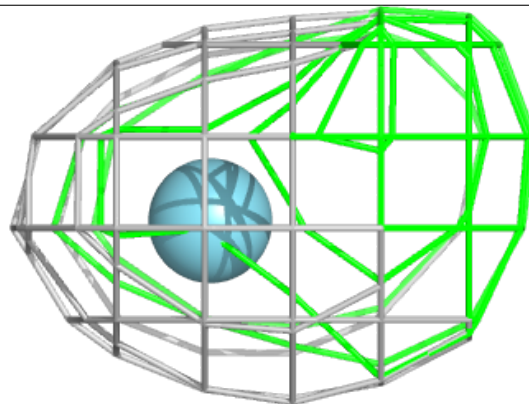
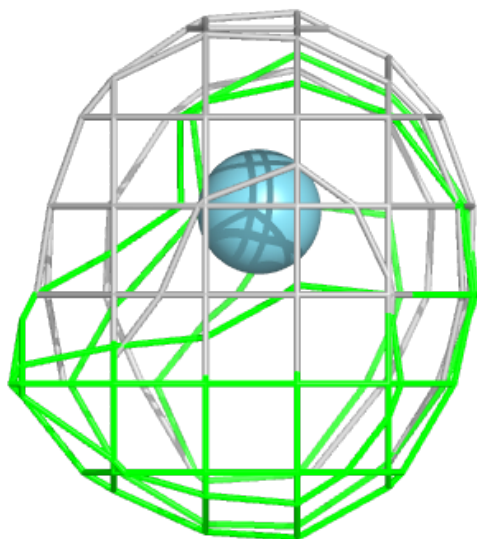
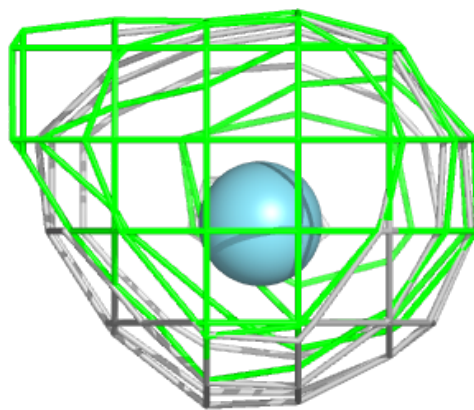

**Electron density around AR A 360:**

$2mF_o-DF_c$  (at 0.7 rmsd) in gray  
 $mF_o-DF_c$  (at 3 rmsd) in purple (negative)  
and green (positive)

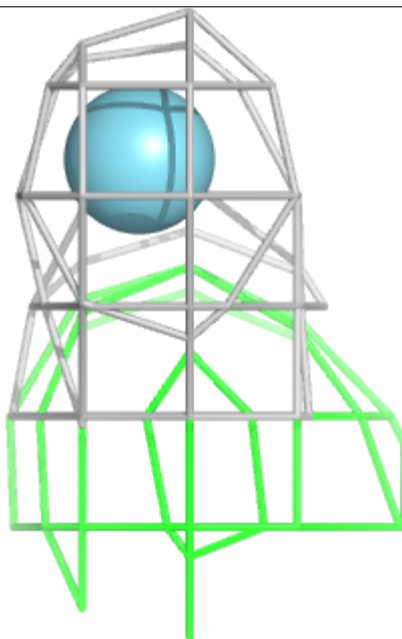
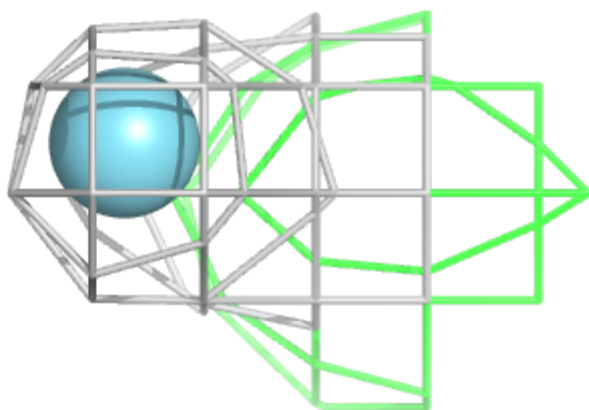
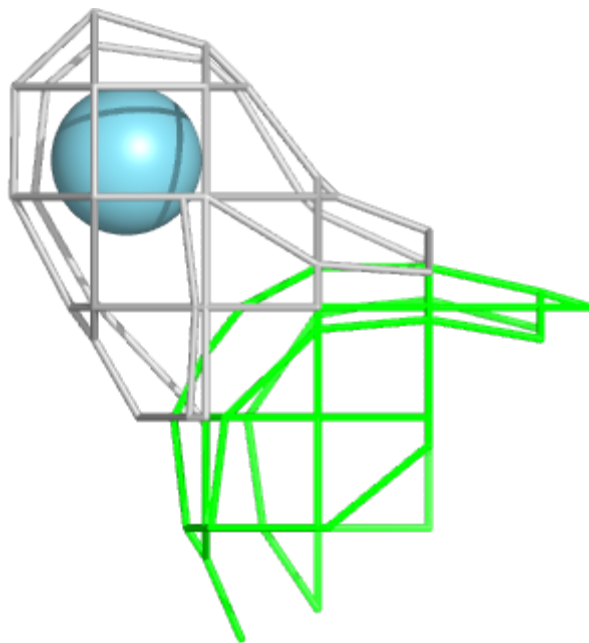



**Electron density around AR A 325:**

$2mF_o-DF_c$  (at 0.7 rmsd) in gray  
 $mF_o-DF_c$  (at 3 rmsd) in purple (negative)  
and green (positive)

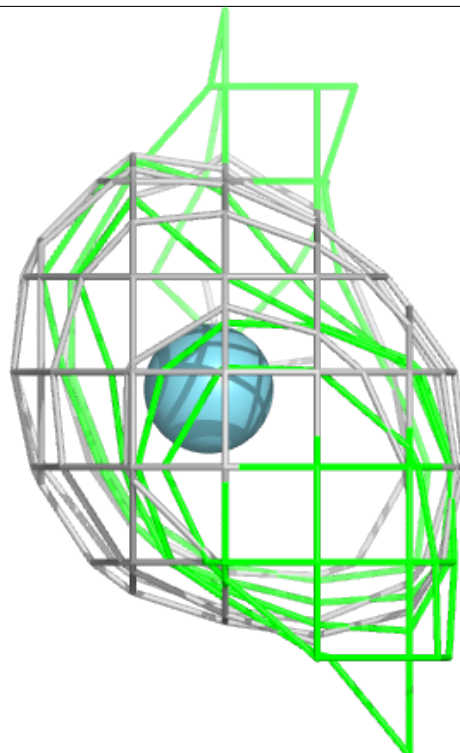
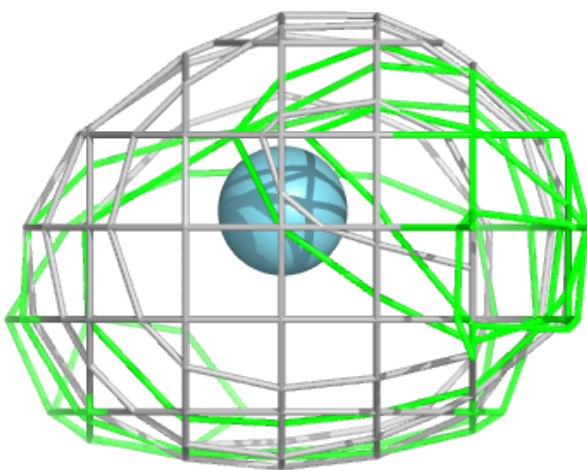
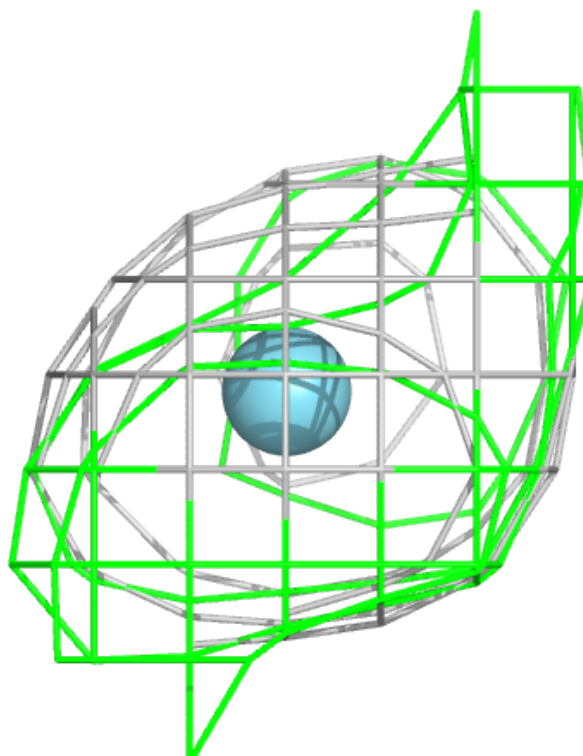

**Electron density around AR A 355:**

$2mF_o-DF_c$  (at 0.7 rmsd) in gray  
 $mF_o-DF_c$  (at 3 rmsd) in purple (negative)  
and green (positive)

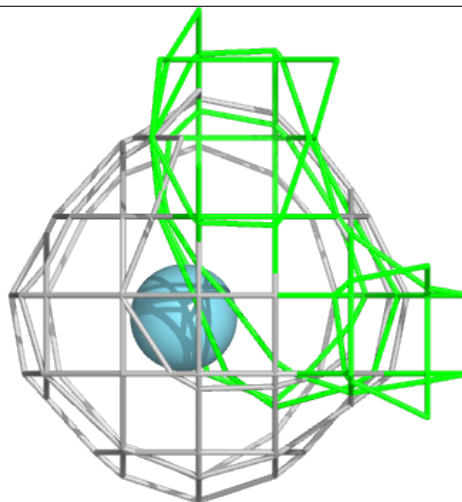
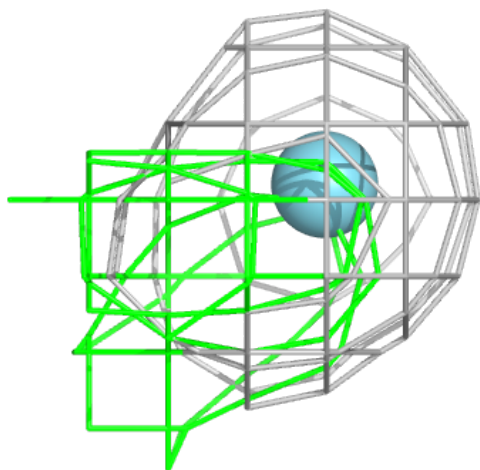
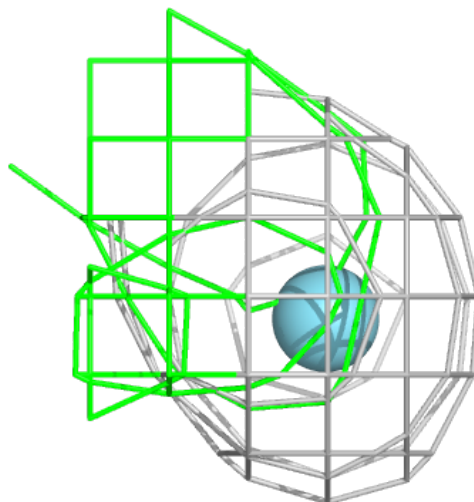

**Electron density around AR A 356:**

$2mF_o-DF_c$  (at 0.7 rmsd) in gray  
 $mF_o-DF_c$  (at 3 rmsd) in purple (negative)  
and green (positive)

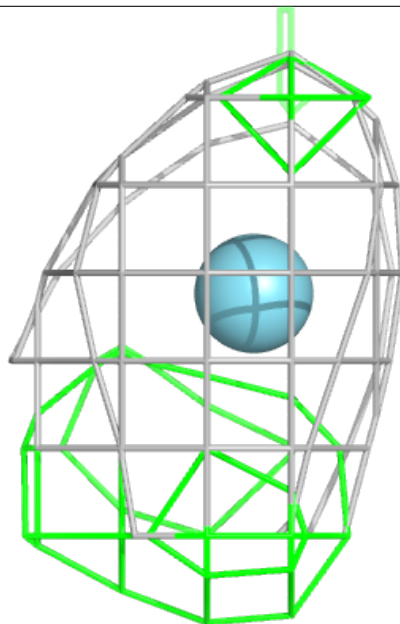
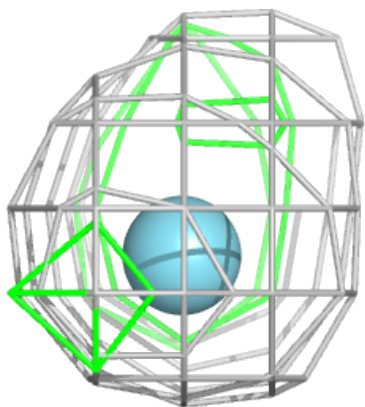
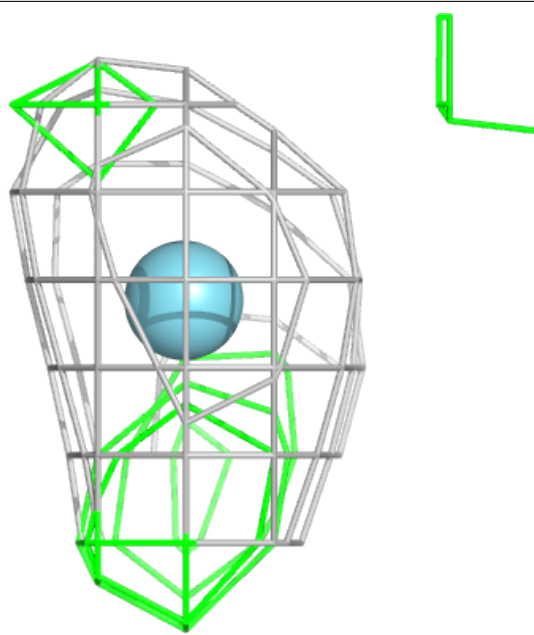

**Electron density around AR A 330:**

$2mF_o-DF_c$  (at 0.7 rmsd) in gray  
 $mF_o-DF_c$  (at 3 rmsd) in purple (negative)  
and green (positive)

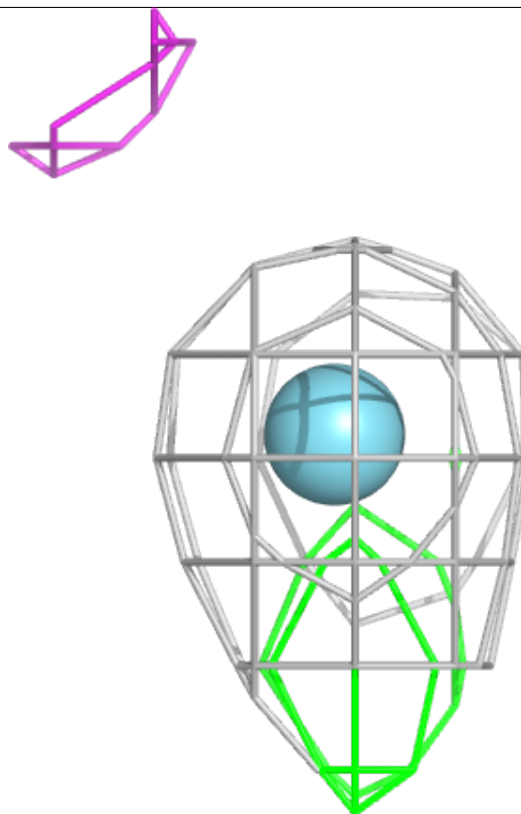
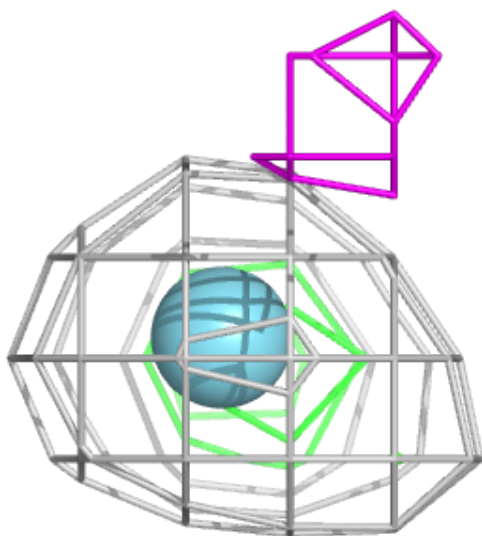
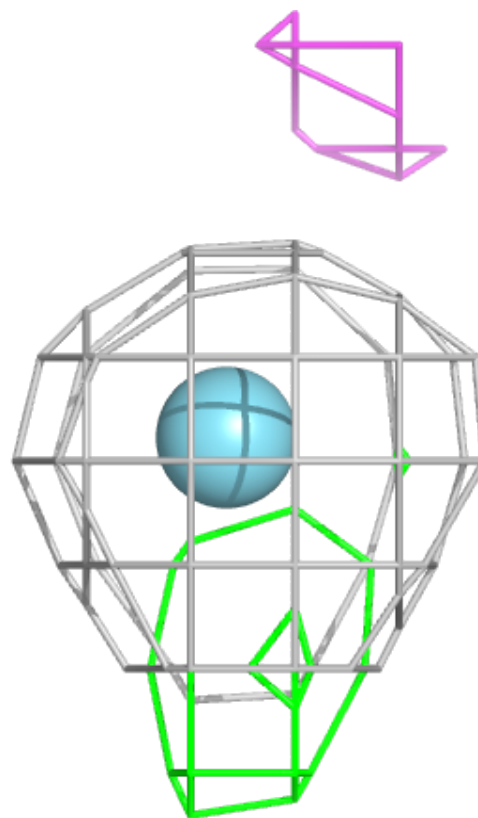

**Electron density around AR A 353:**

$2mF_o-DF_c$  (at 0.7 rmsd) in gray  
 $mF_o-DF_c$  (at 3 rmsd) in purple (negative)  
and green (positive)

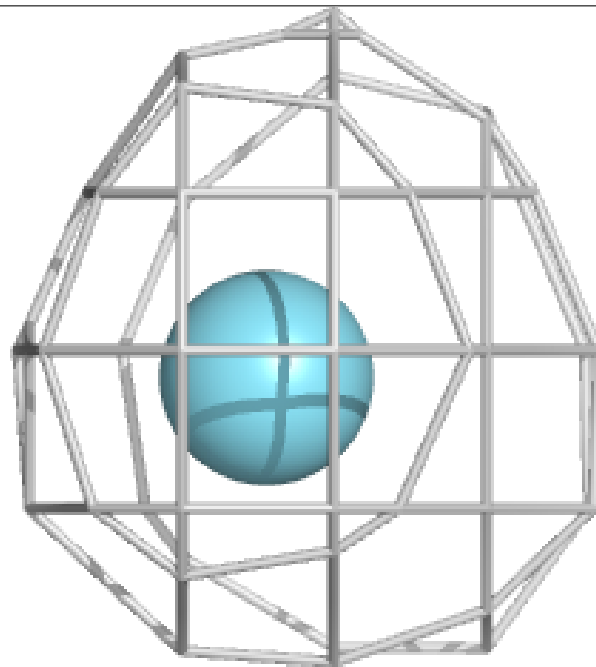
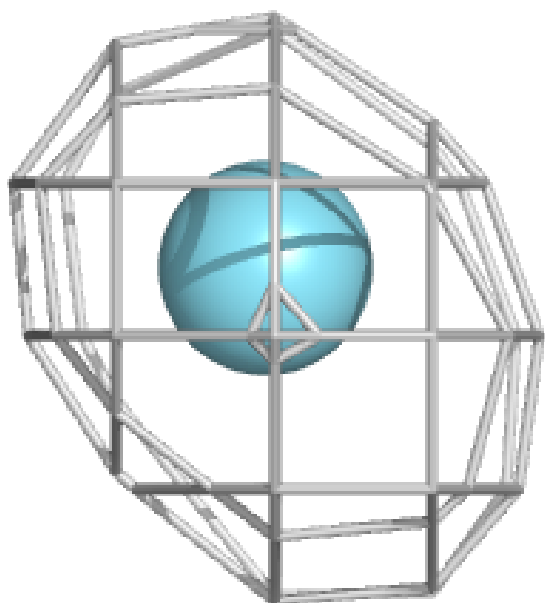
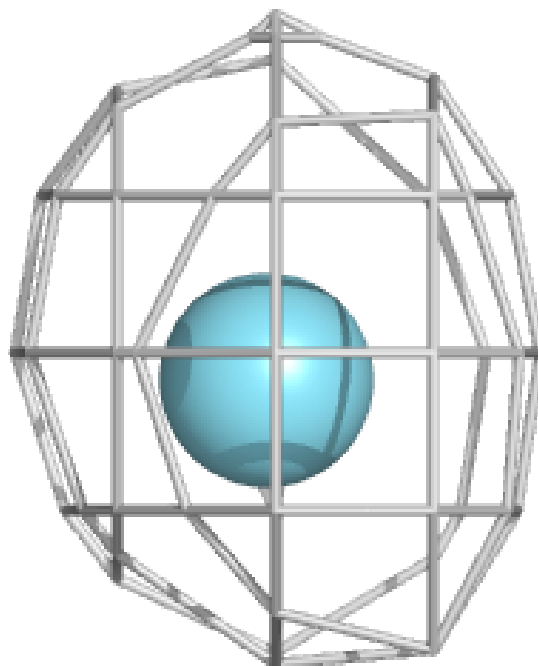

**Electron density around AR A 354:**

$2mF_o-DF_c$  (at 0.7 rmsd) in gray  
 $mF_o-DF_c$  (at 3 rmsd) in purple (negative)  
and green (positive)

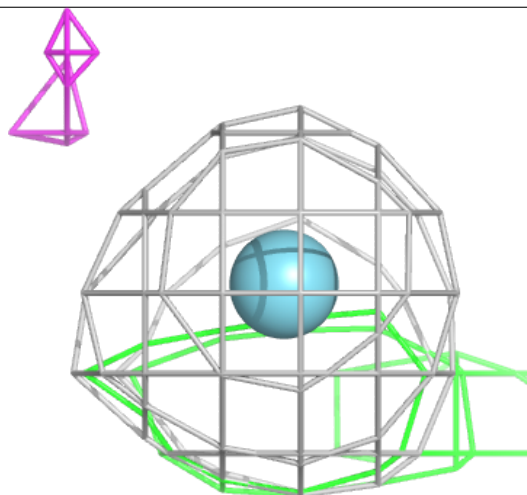
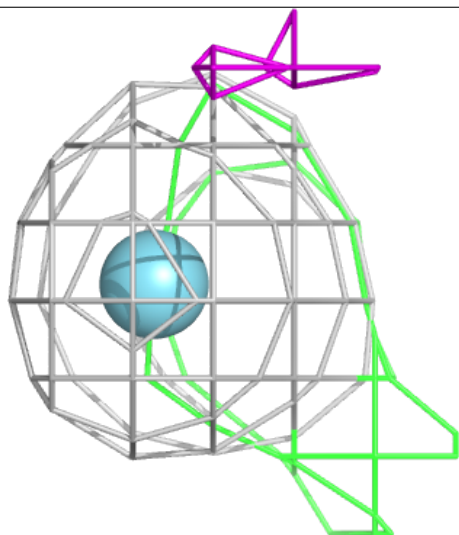
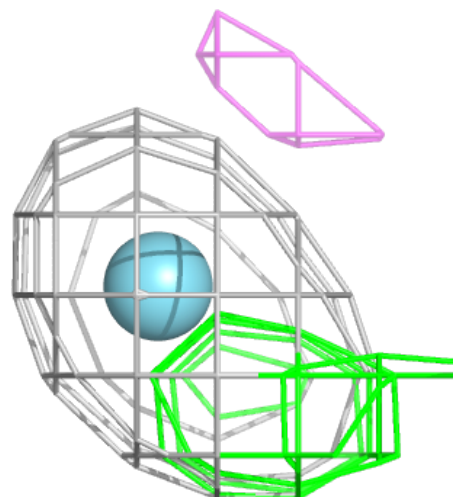

**Electron density around AR A 368:**

$2mF_o-DF_c$  (at 0.7 rmsd) in gray  
 $mF_o-DF_c$  (at 3 rmsd) in purple (negative)  
and green (positive)

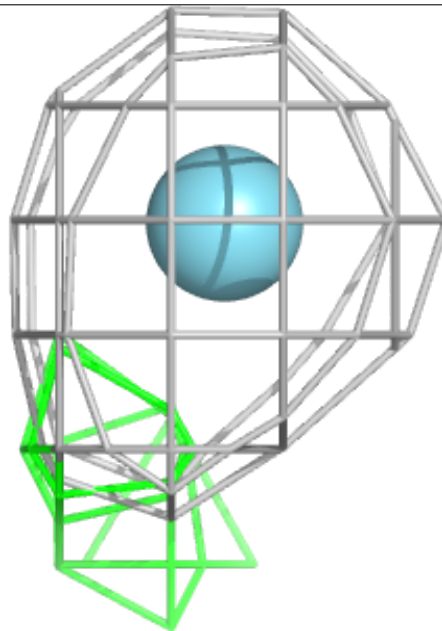
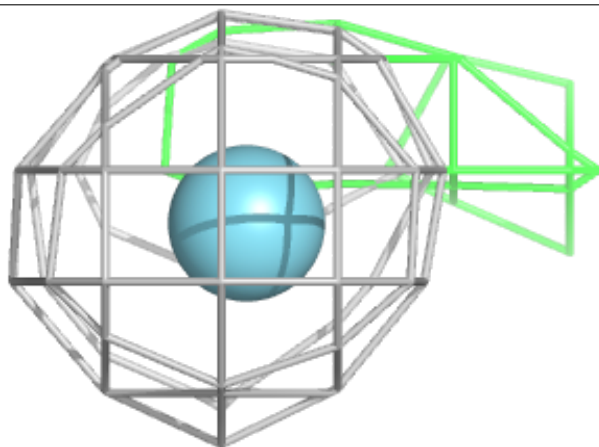
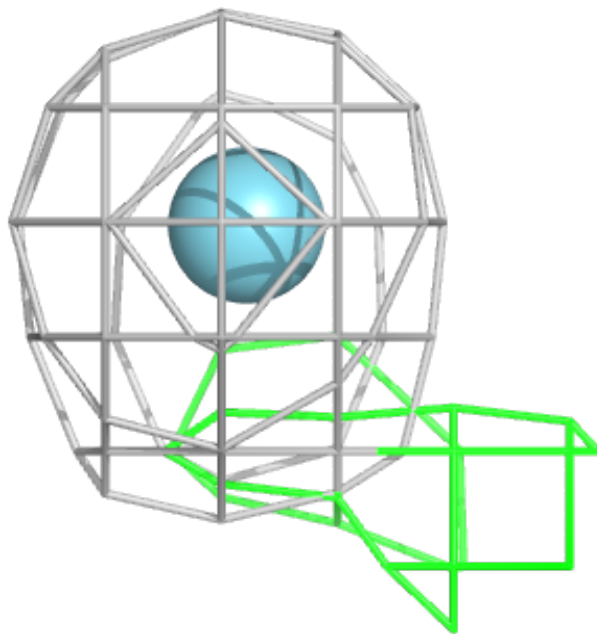

**Electron density around AR A 342:**

$2mF_o-DF_c$  (at 0.7 rmsd) in gray  
 $mF_o-DF_c$  (at 3 rmsd) in purple (negative)  
and green (positive)

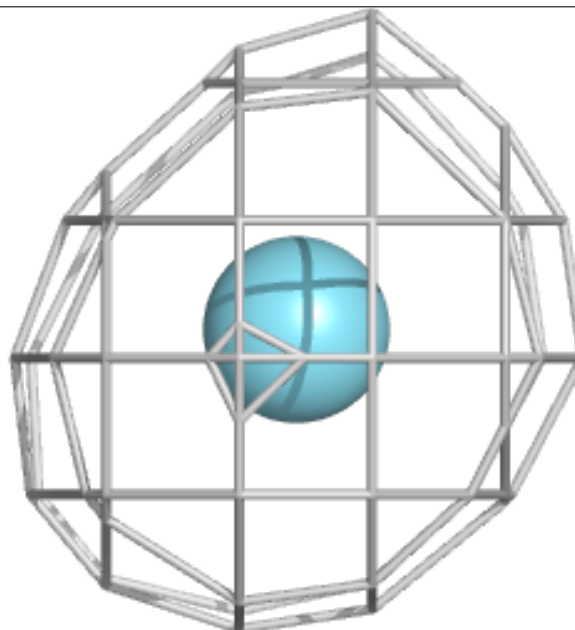
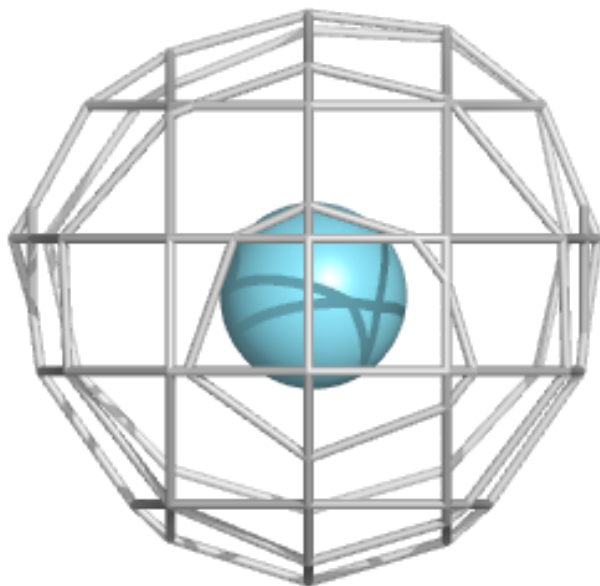
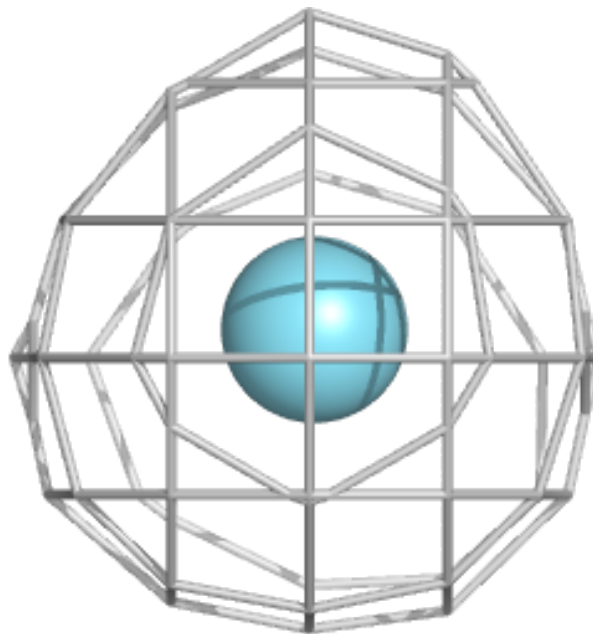



**Electron density around AR A 344:**

$2mF_o-DF_c$  (at 0.7 rmsd) in gray  
 $mF_o-DF_c$  (at 3 rmsd) in purple (negative)  
and green (positive)

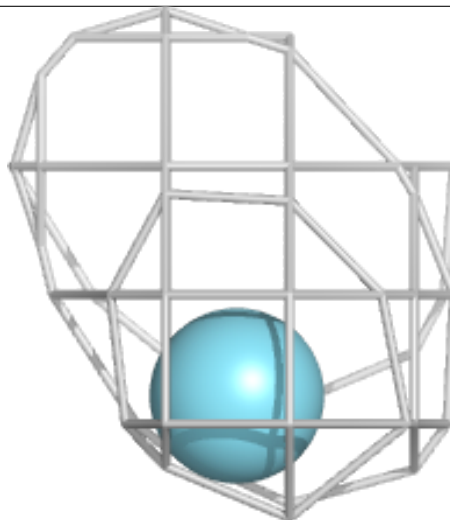
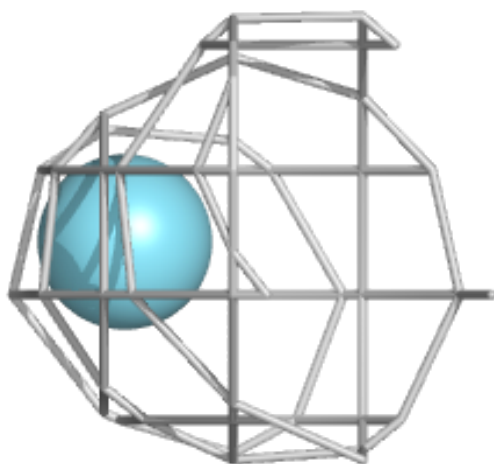
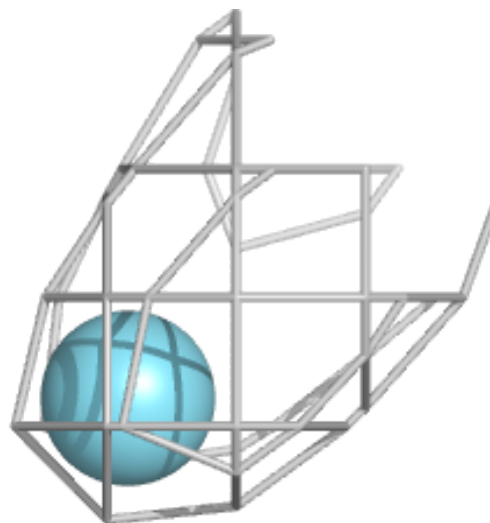

**Electron density around AR A 346:**

$2mF_o-DF_c$  (at 0.7 rmsd) in gray  
 $mF_o-DF_c$  (at 3 rmsd) in purple (negative)  
and green (positive)

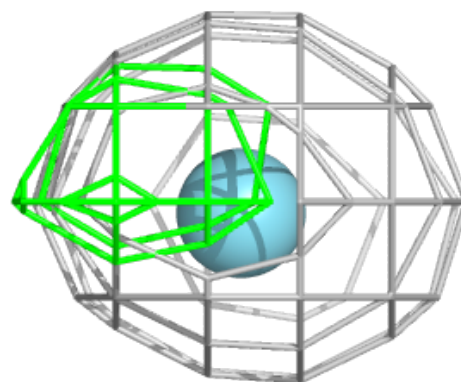
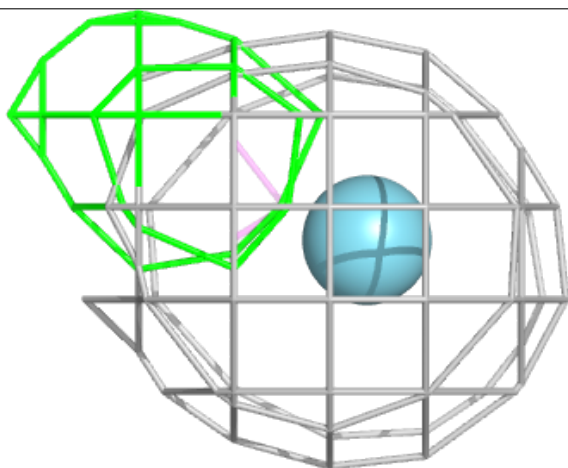
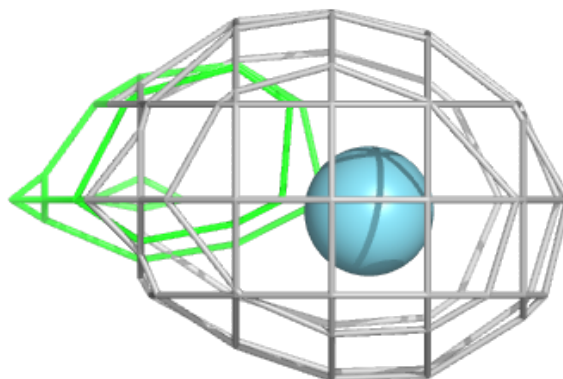

**Electron density around AR A 339:**

$2mF_o-DF_c$  (at 0.7 rmsd) in gray  
 $mF_o-DF_c$  (at 3 rmsd) in purple (negative)  
and green (positive)

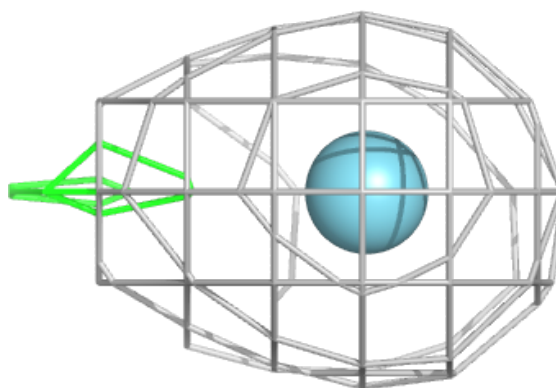
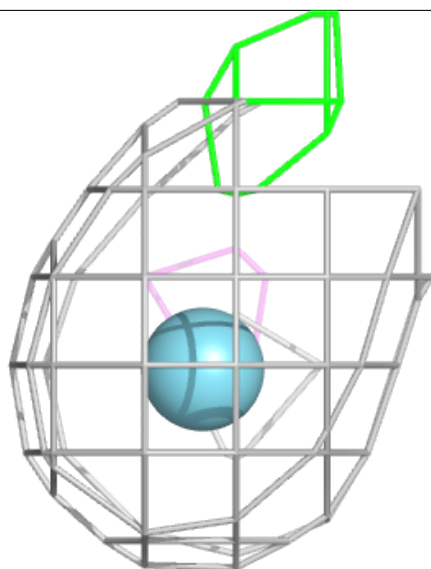
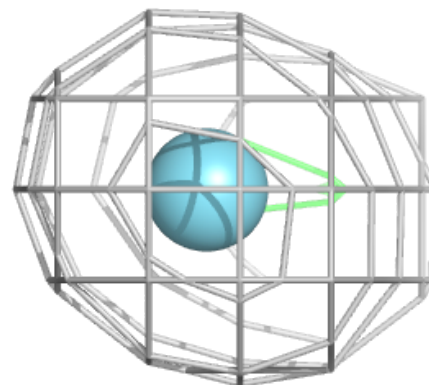

**Electron density around AR A 328:**

$2mF_o-DF_c$  (at 0.7 rmsd) in gray  
 $mF_o-DF_c$  (at 3 rmsd) in purple (negative)  
and green (positive)

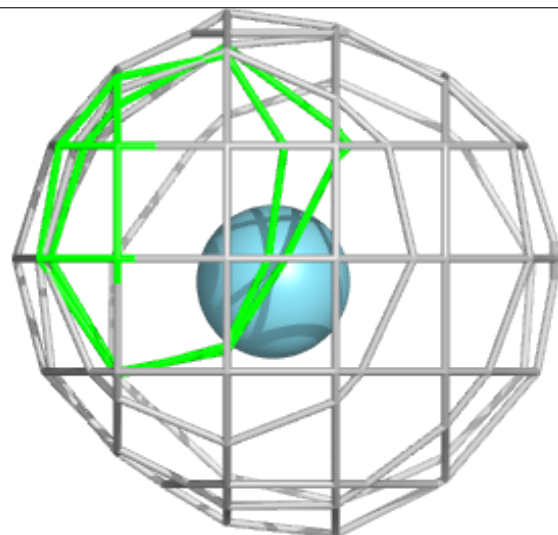
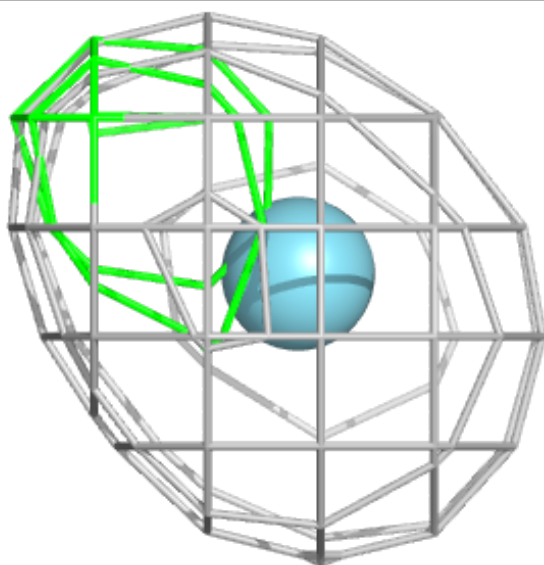
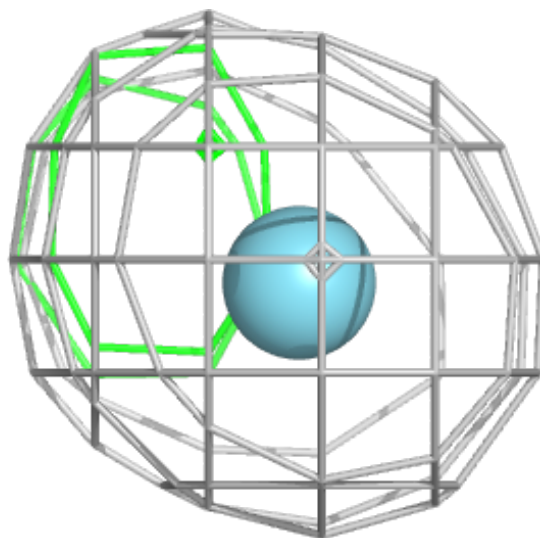

**Electron density around AR A 361:**

$2mF_o-DF_c$  (at 0.7 rmsd) in gray  
 $mF_o-DF_c$  (at 3 rmsd) in purple (negative)  
and green (positive)

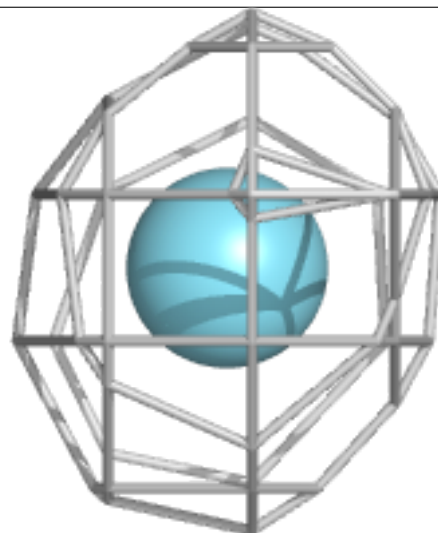
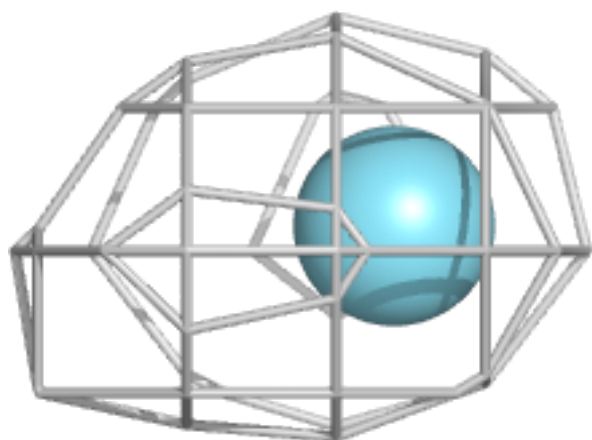
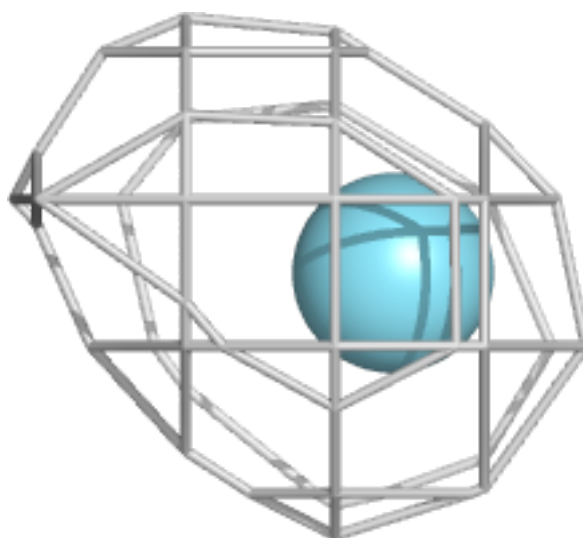

**Electron density around AR A 347:**

$2mF_o-DF_c$  (at 0.7 rmsd) in gray  
 $mF_o-DF_c$  (at 3 rmsd) in purple (negative)  
and green (positive)

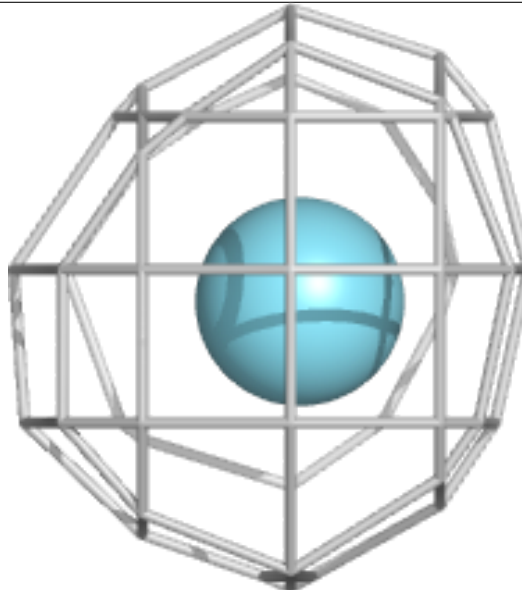
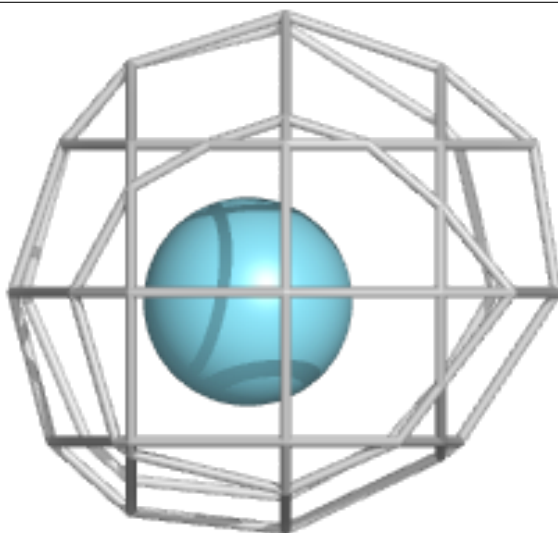
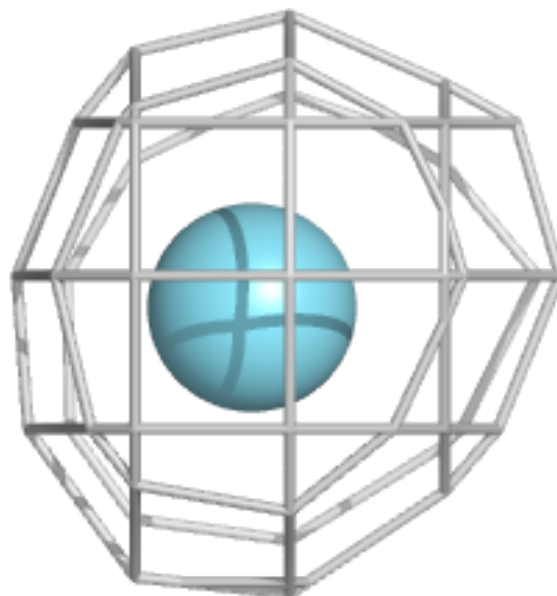

**Electron density around AR A 329:**

$2mF_o-DF_c$  (at 0.7 rmsd) in gray  
 $mF_o-DF_c$  (at 3 rmsd) in purple (negative)  
and green (positive)

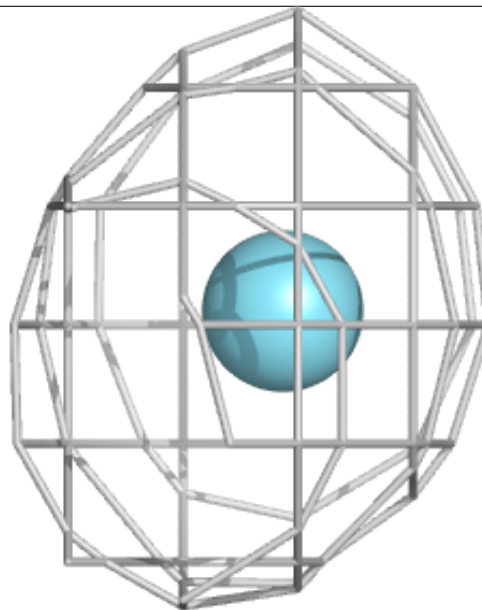
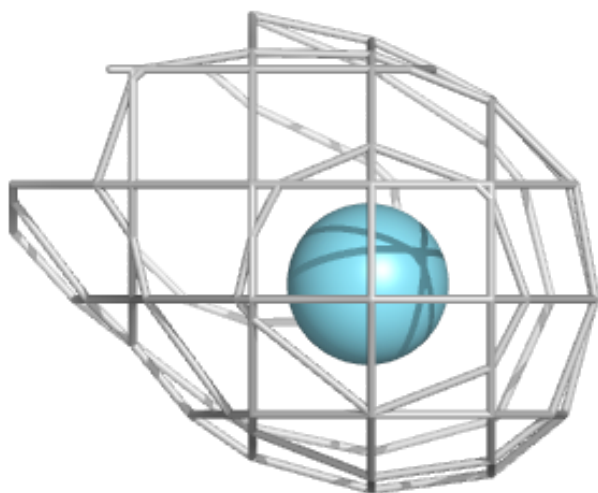
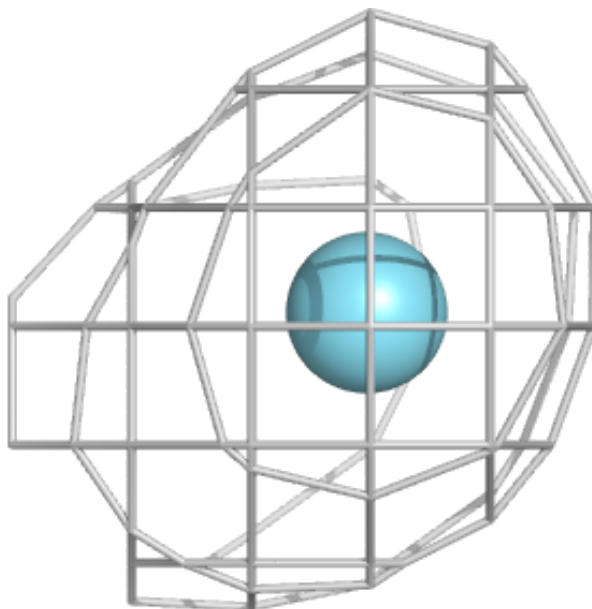

**Electron density around AR A 341:**

$2mF_o-DF_c$  (at 0.7 rmsd) in gray  
 $mF_o-DF_c$  (at 3 rmsd) in purple (negative)  
and green (positive)

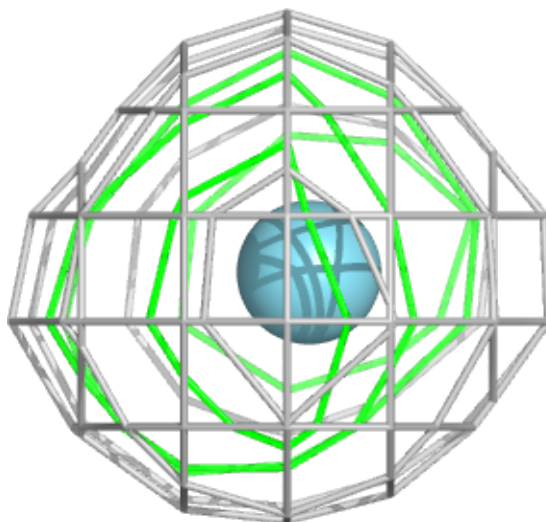
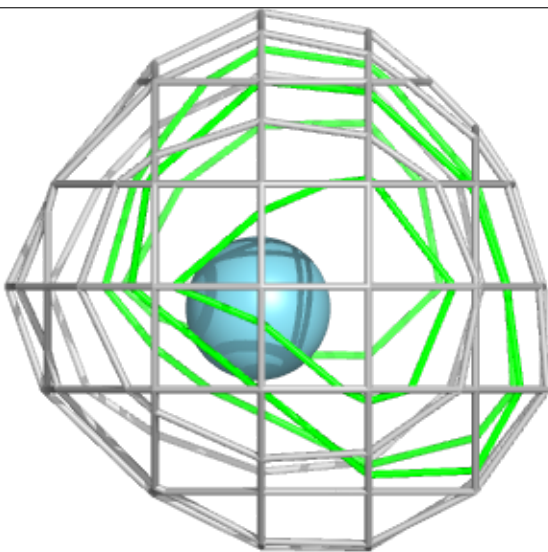
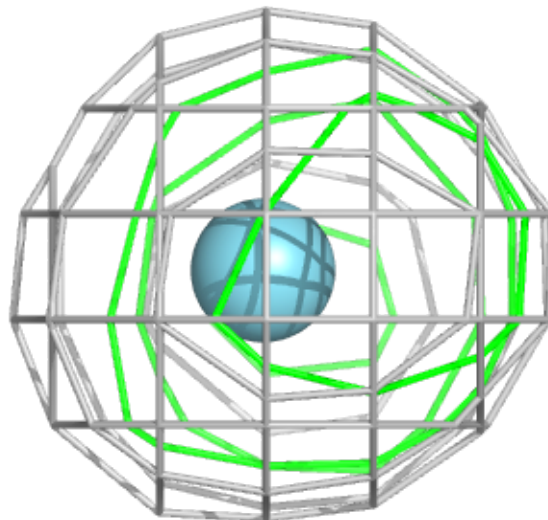



**Electron density around AR A 350:**

$2mF_o-DF_c$  (at 0.7 rmsd) in gray  
 $mF_o-DF_c$  (at 3 rmsd) in purple (negative)  
and green (positive)

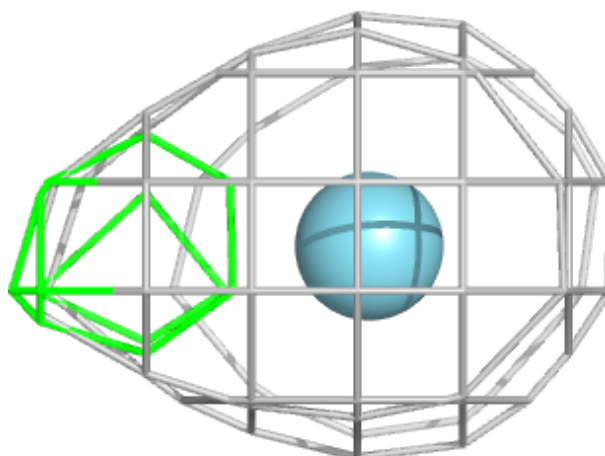
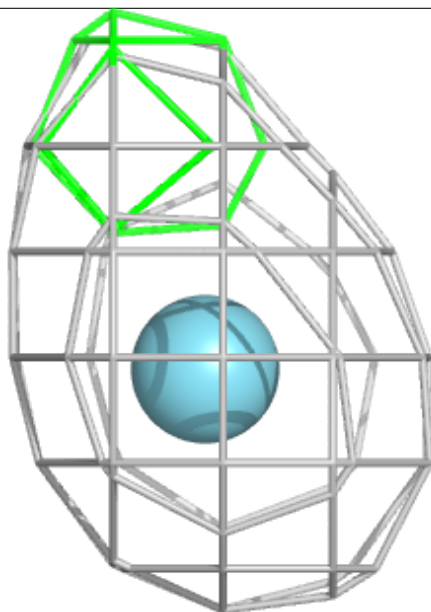
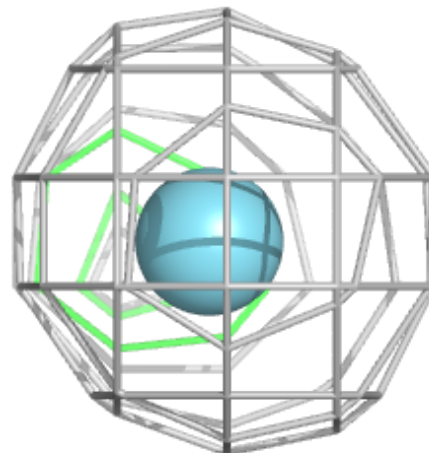

**Electron density around AR A 352:**

$2mF_o-DF_c$  (at 0.7 rmsd) in gray  
 $mF_o-DF_c$  (at 3 rmsd) in purple (negative)  
and green (positive)

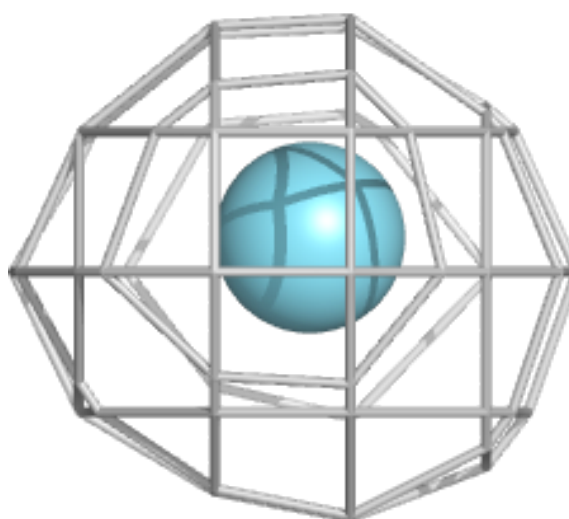
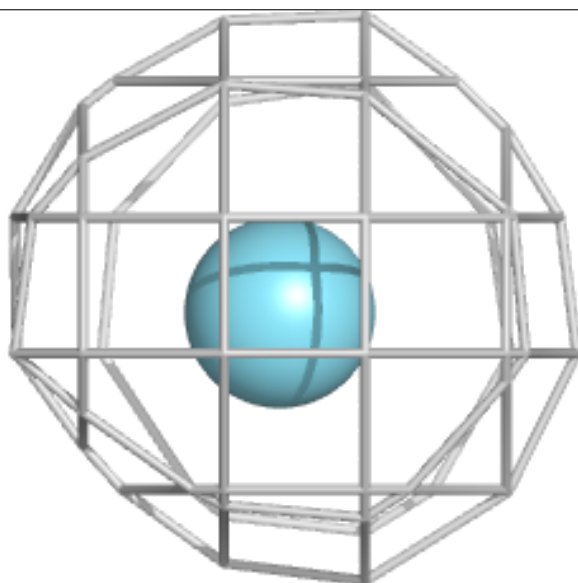
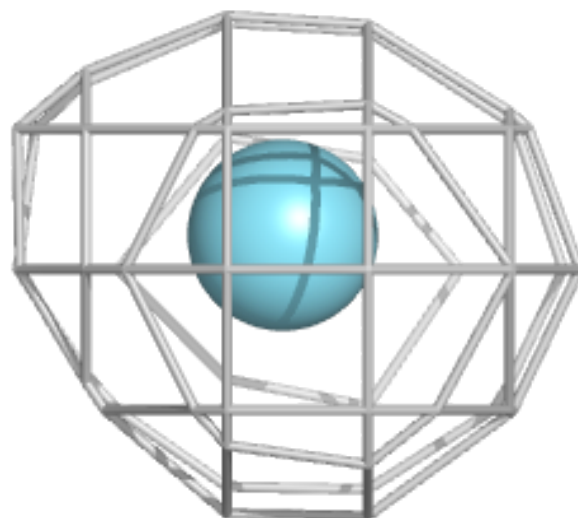

**Electron density around AR A 337:**

$2mF_o-DF_c$  (at 0.7 rmsd) in gray  
 $mF_o-DF_c$  (at 3 rmsd) in purple (negative)  
and green (positive)

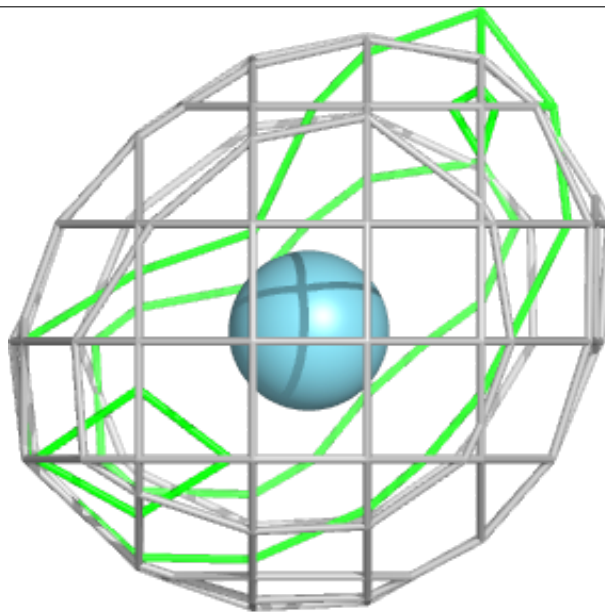
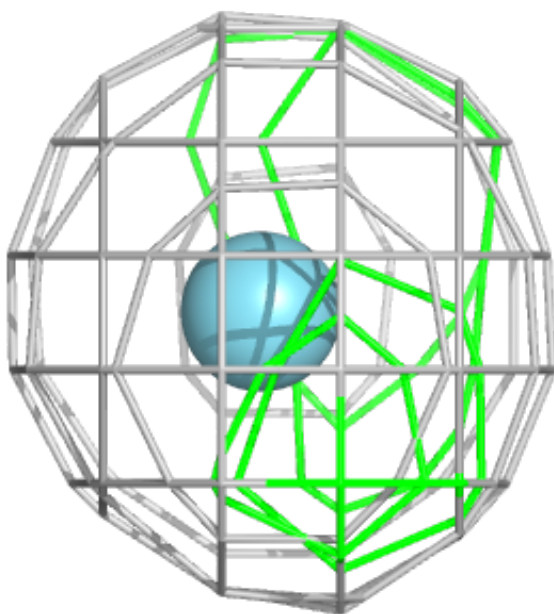
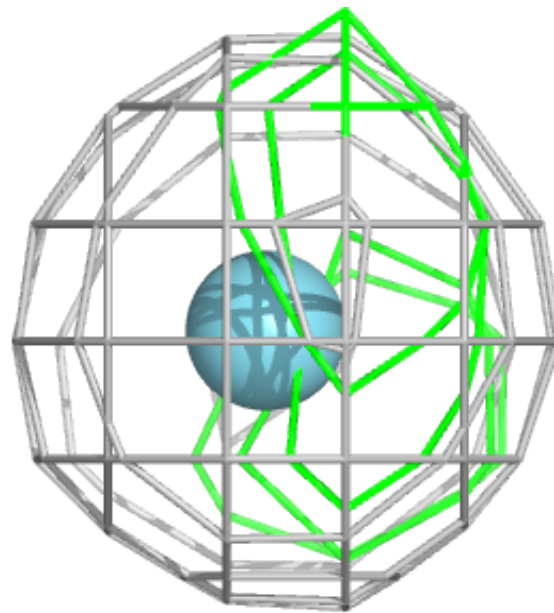

**Electron density around AR A 335:**

$2mF_o-DF_c$  (at 0.7 rmsd) in gray  
 $mF_o-DF_c$  (at 3 rmsd) in purple (negative)  
and green (positive)

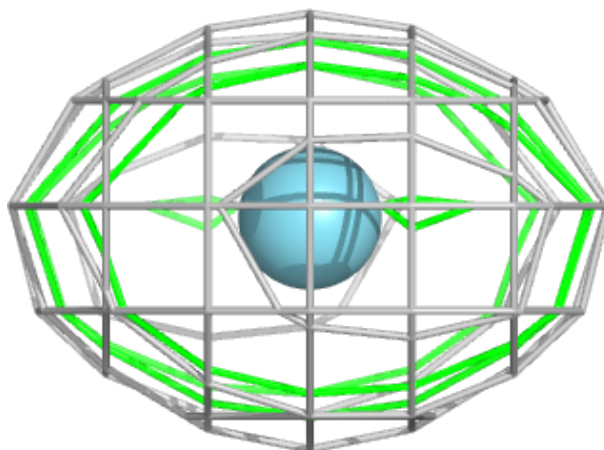
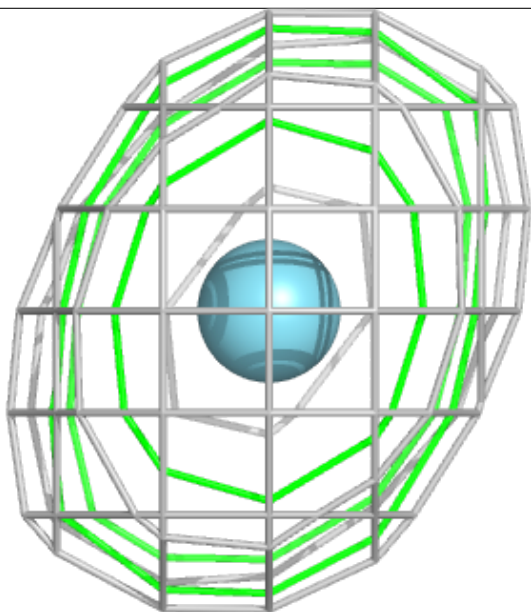
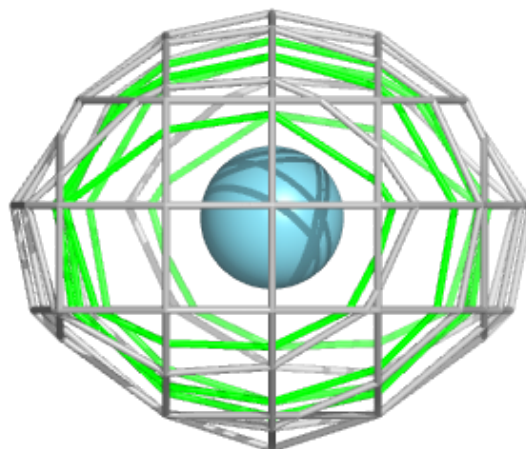

**Electron density around AR A 358:**

$2mF_o-DF_c$  (at 0.7 rmsd) in gray  
 $mF_o-DF_c$  (at 3 rmsd) in purple (negative)  
and green (positive)

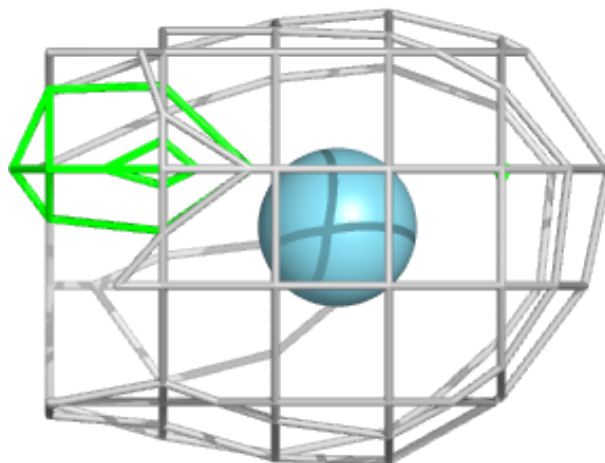
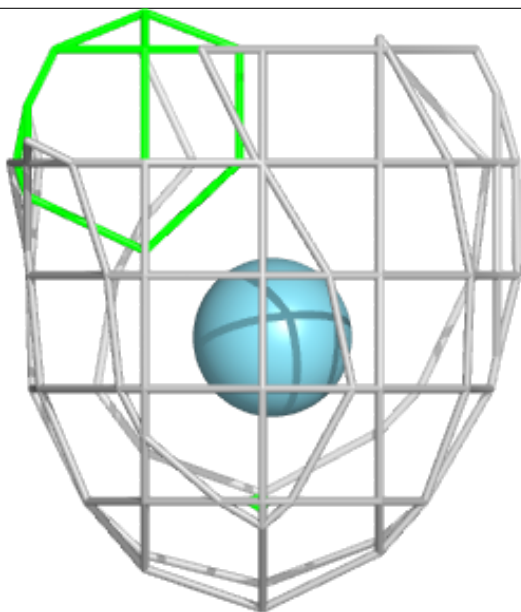
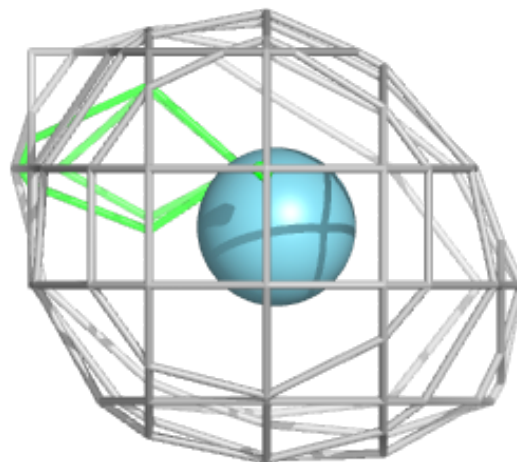

**Electron density around AR A 333:**

$2mF_o-DF_c$  (at 0.7 rmsd) in gray  
 $mF_o-DF_c$  (at 3 rmsd) in purple (negative)  
and green (positive)

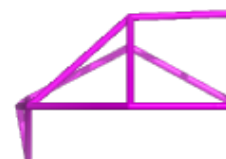
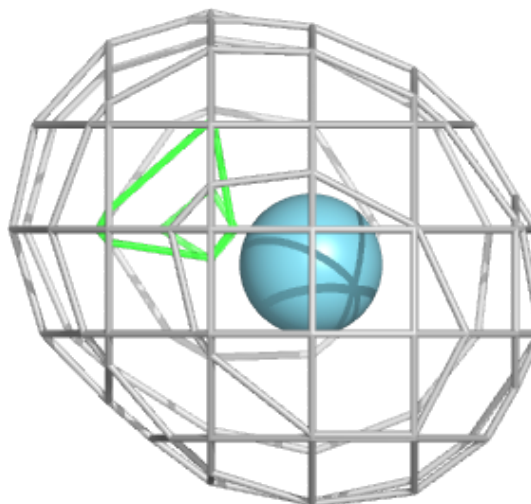
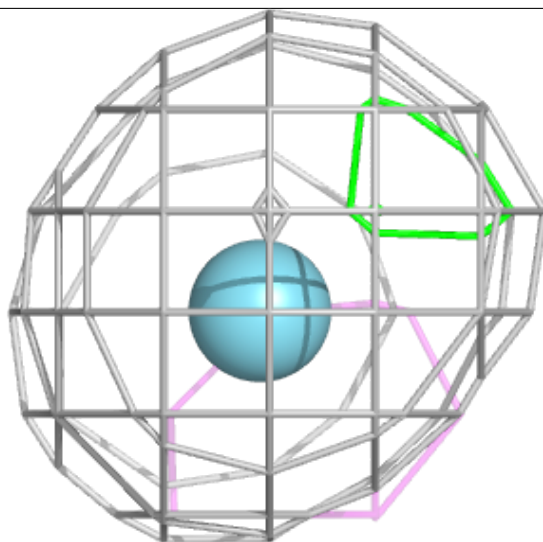
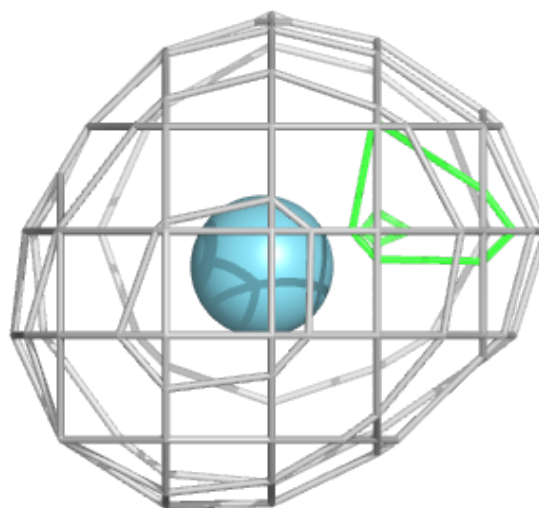

**Electron density around AR A 332:**

$2mF_o-DF_c$  (at 0.7 rmsd) in gray  
 $mF_o-DF_c$  (at 3 rmsd) in purple (negative)  
and green (positive)

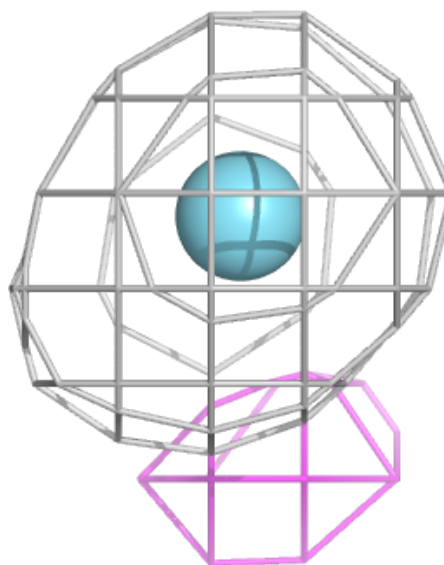
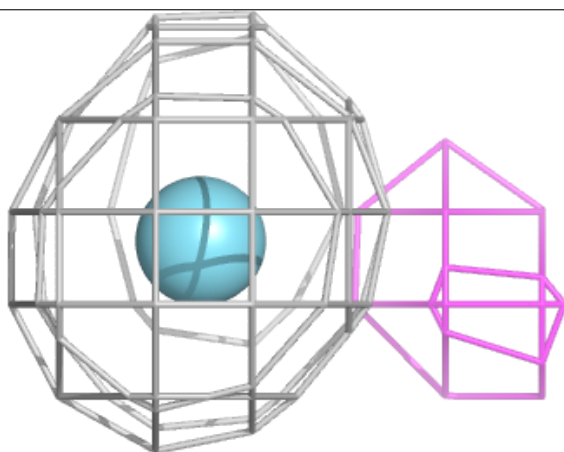
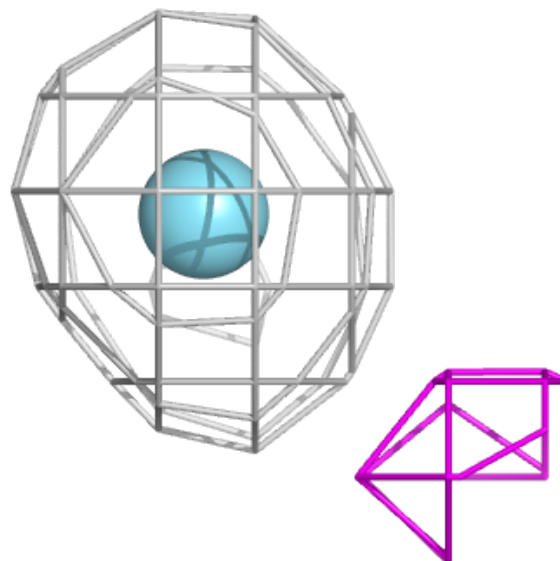



**Electron density around AR A 362:**

$2mF_o-DF_c$  (at 0.7 rmsd) in gray  
 $mF_o-DF_c$  (at 3 rmsd) in purple (negative)  
and green (positive)

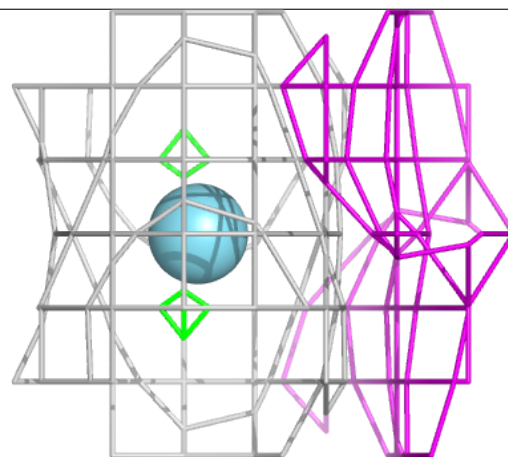
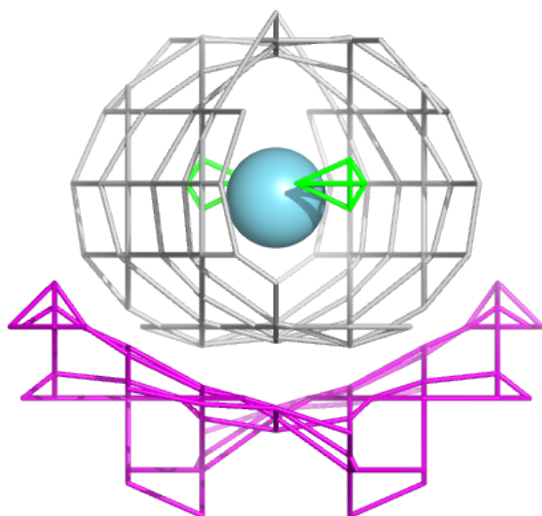
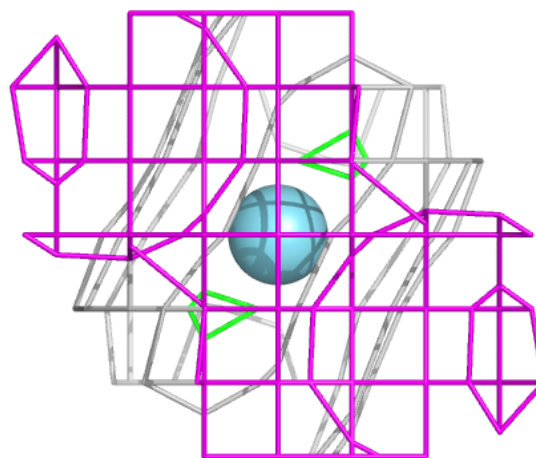



**Electron density around AR A 327:**

$2mF_o-DF_c$  (at 0.7 rmsd) in gray  
 $mF_o-DF_c$  (at 3 rmsd) in purple (negative)  
and green (positive)

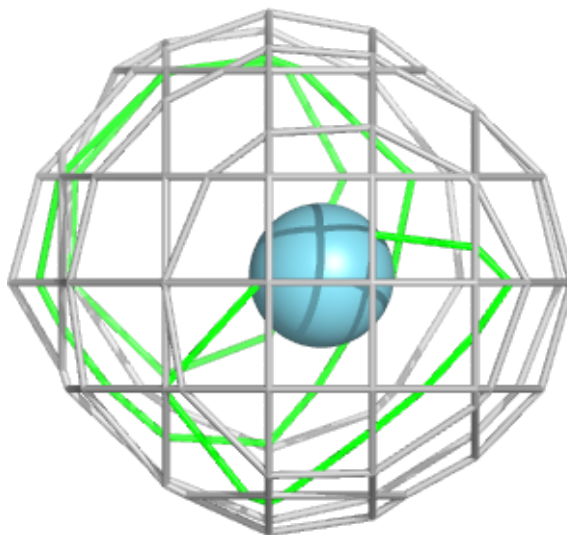
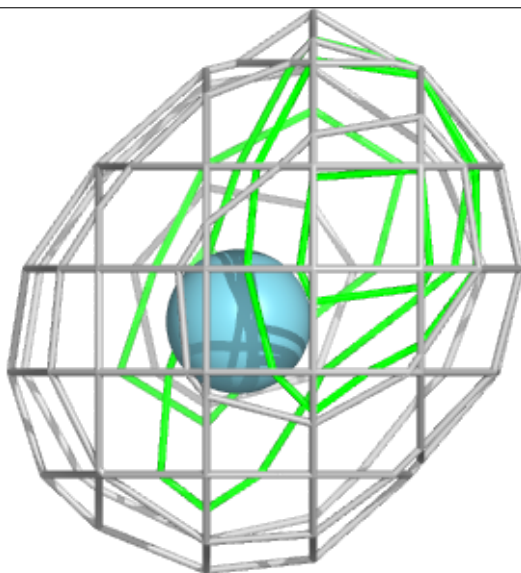
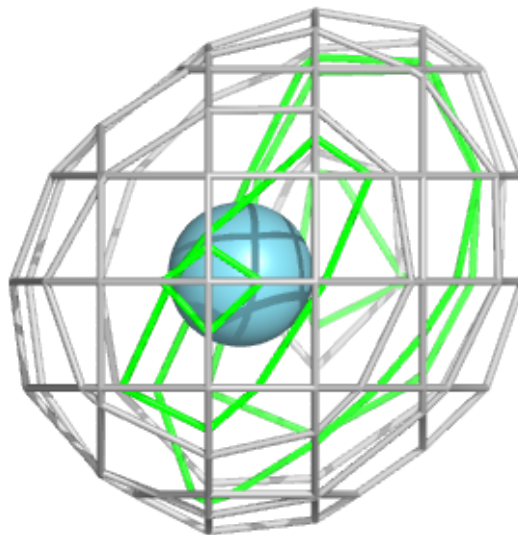

**Electron density around AR A 348:**

$2mF_o-DF_c$  (at 0.7 rmsd) in gray  
 $mF_o-DF_c$  (at 3 rmsd) in purple (negative)  
and green (positive)

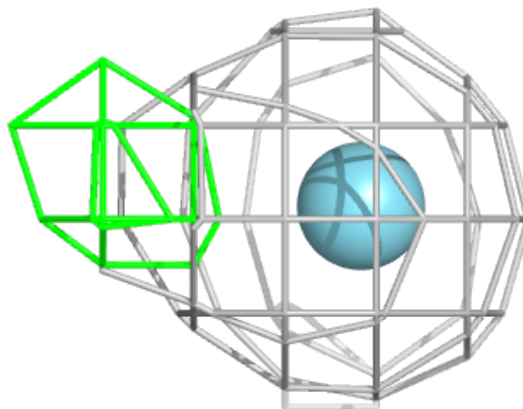
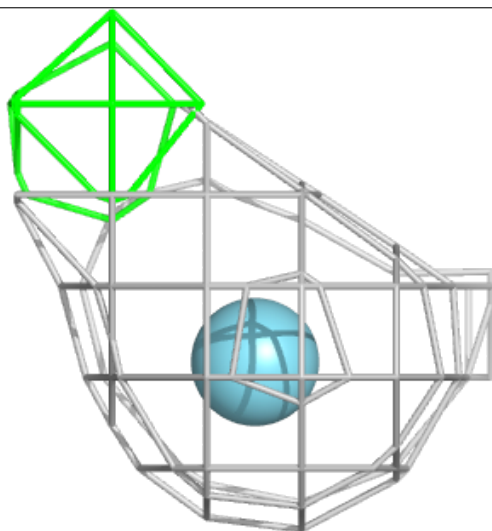
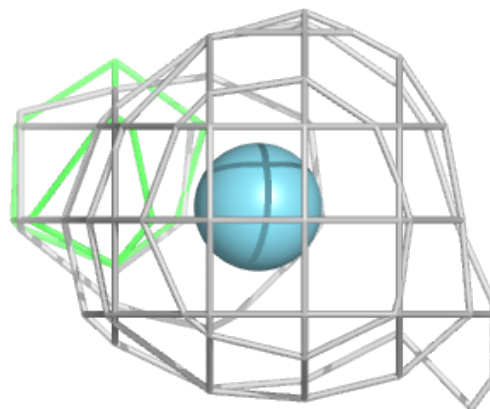

**Electron density around AR A 338:**

$2mF_o-DF_c$  (at 0.7 rmsd) in gray  
 $mF_o-DF_c$  (at 3 rmsd) in purple (negative)  
and green (positive)

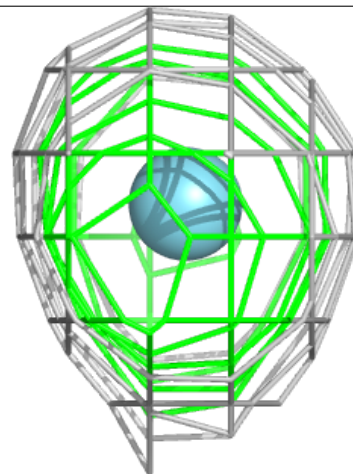
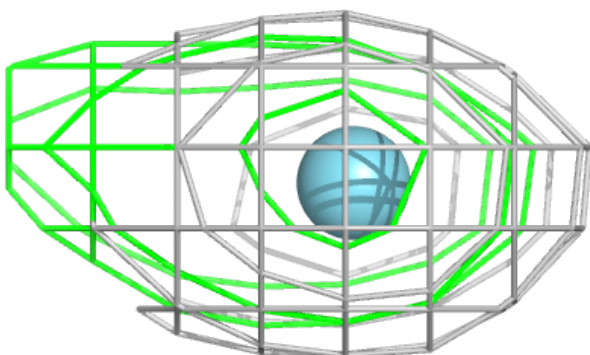
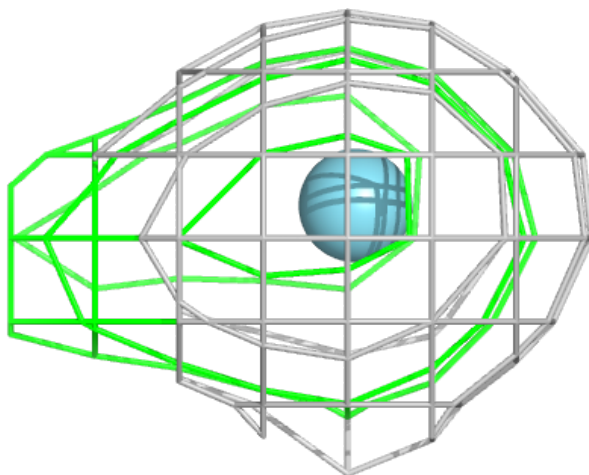

**Electron density around AR A 351:**

$2mF_o-DF_c$  (at 0.7 rmsd) in gray  
 $mF_o-DF_c$  (at 3 rmsd) in purple (negative)  
and green (positive)

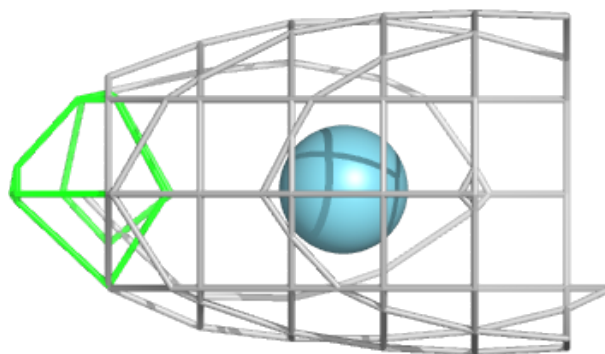
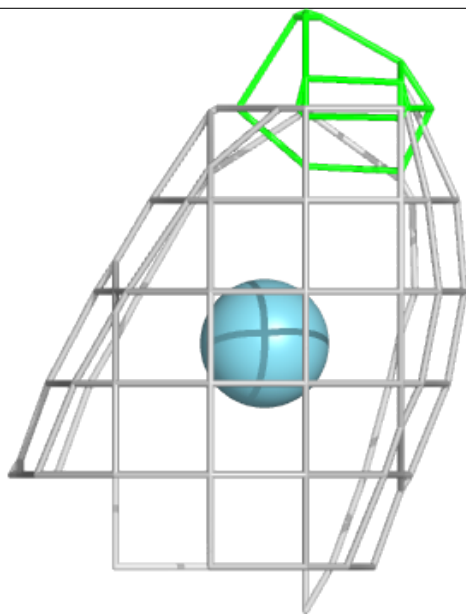
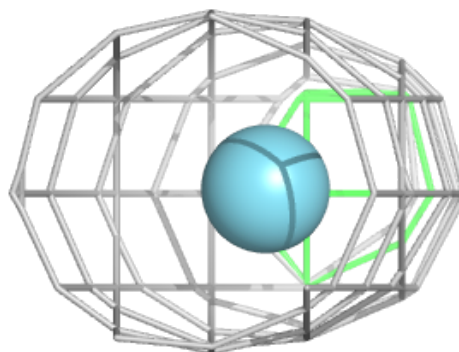

**Electron density around AR A 343:**

$2mF_o-DF_c$  (at 0.7 rmsd) in gray  
 $mF_o-DF_c$  (at 3 rmsd) in purple (negative)  
and green (positive)

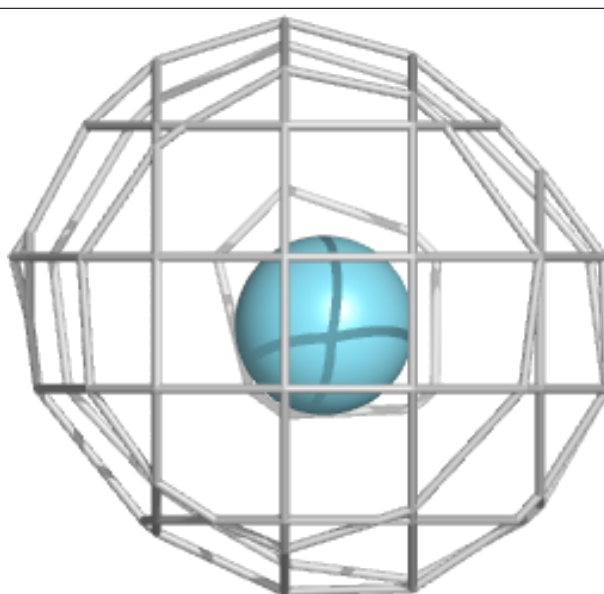
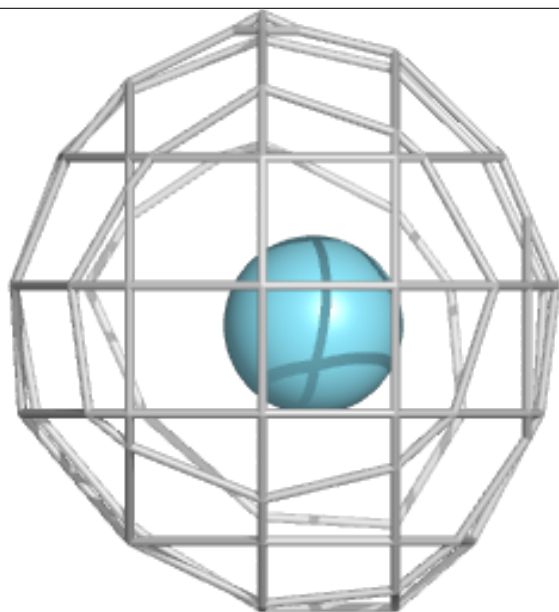

**Electron density around AR A 331:**

$2mF_o-DF_c$  (at 0.7 rmsd) in gray  
 $mF_o-DF_c$  (at 3 rmsd) in purple (negative)  
and green (positive)

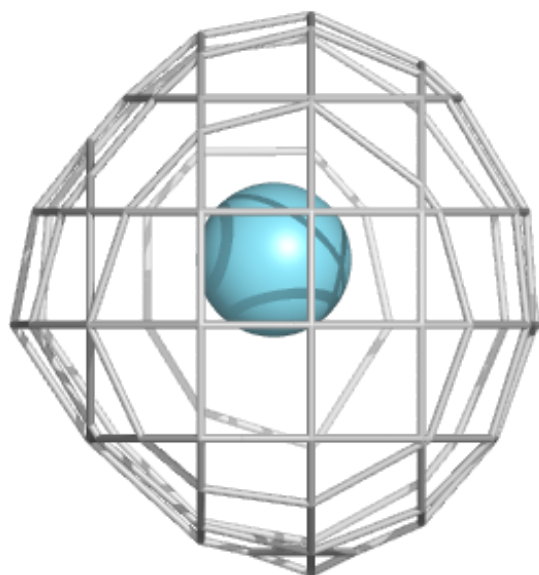
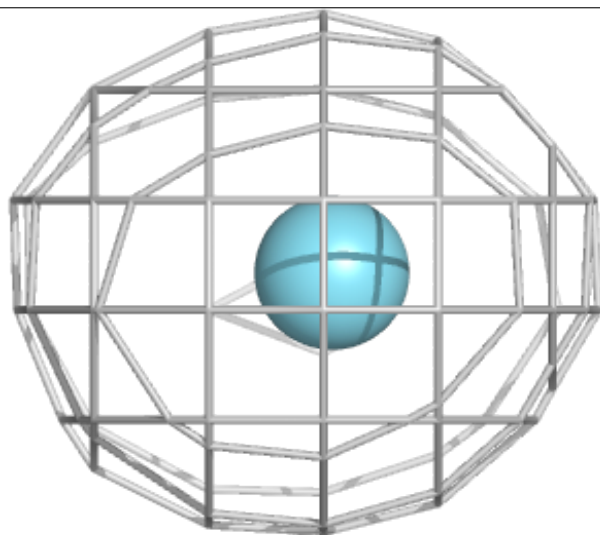
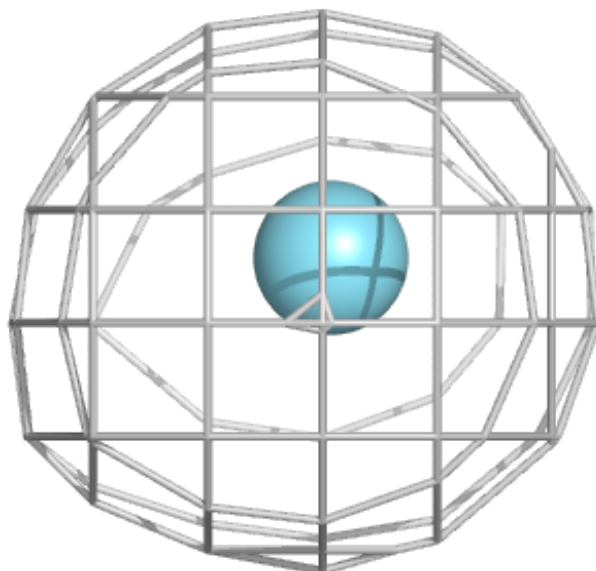

**Electron density around AR A 349:**

$2mF_o-DF_c$  (at 0.7 rmsd) in gray  
 $mF_o-DF_c$  (at 3 rmsd) in purple (negative)  
and green (positive)

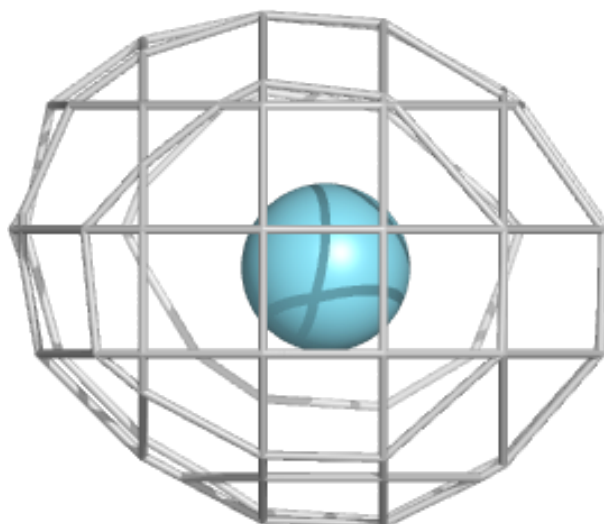
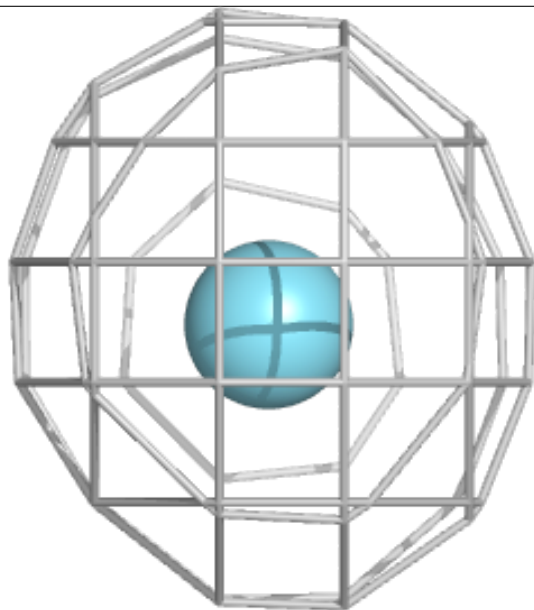
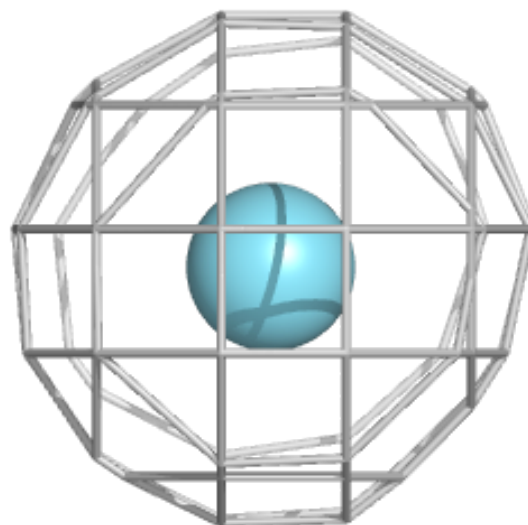

**Electron density around AR A 345:**

$2mF_o-DF_c$  (at 0.7 rmsd) in gray  
 $mF_o-DF_c$  (at 3 rmsd) in purple (negative)  
and green (positive)

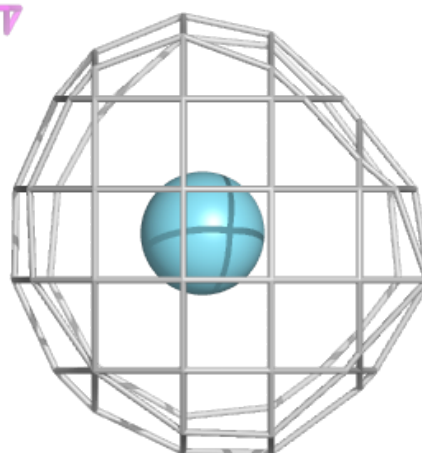
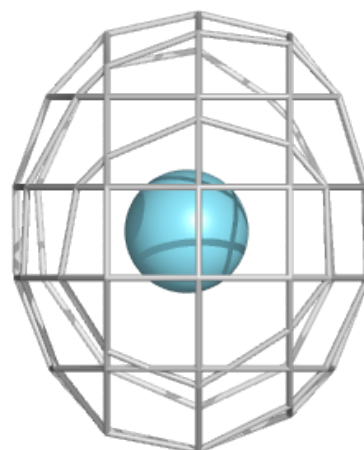



**Electron density around AR A 322:**

$2mF_o-DF_c$  (at 0.7 rmsd) in gray  
 $mF_o-DF_c$  (at 3 rmsd) in purple (negative)  
and green (positive)

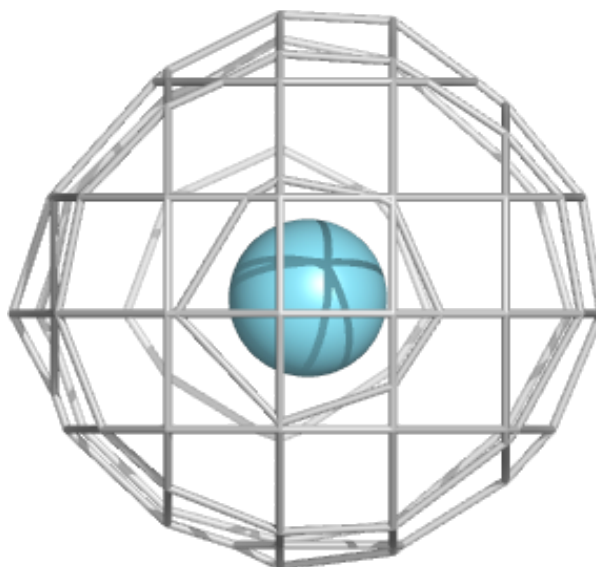
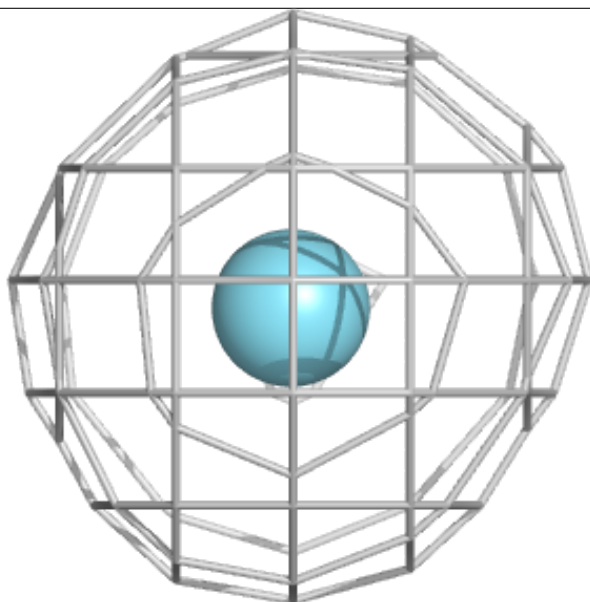
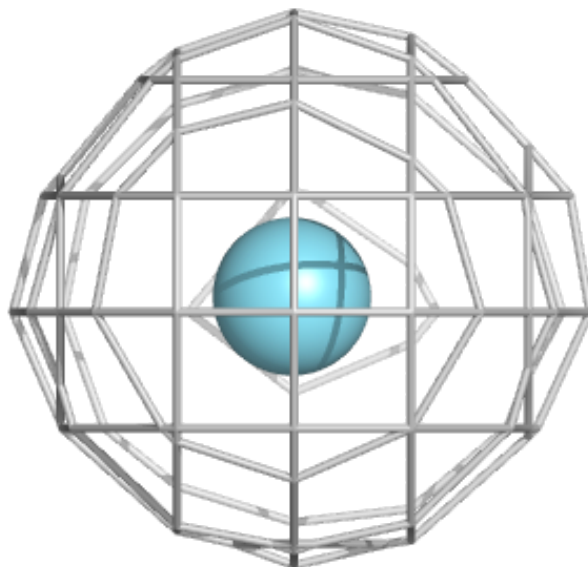

**Electron density around AR A 334:**

$2mF_o-DF_c$  (at 0.7 rmsd) in gray  
 $mF_o-DF_c$  (at 3 rmsd) in purple (negative)  
and green (positive)

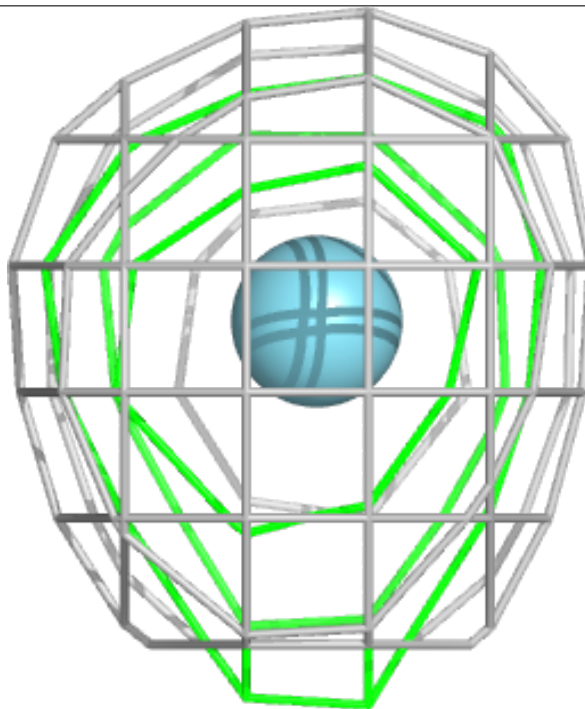
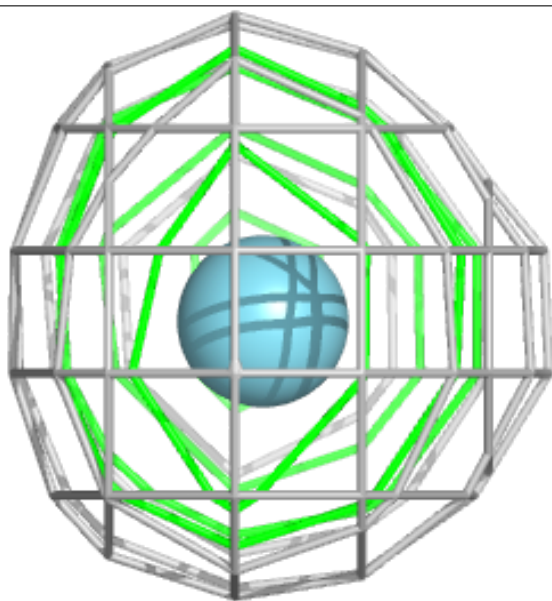
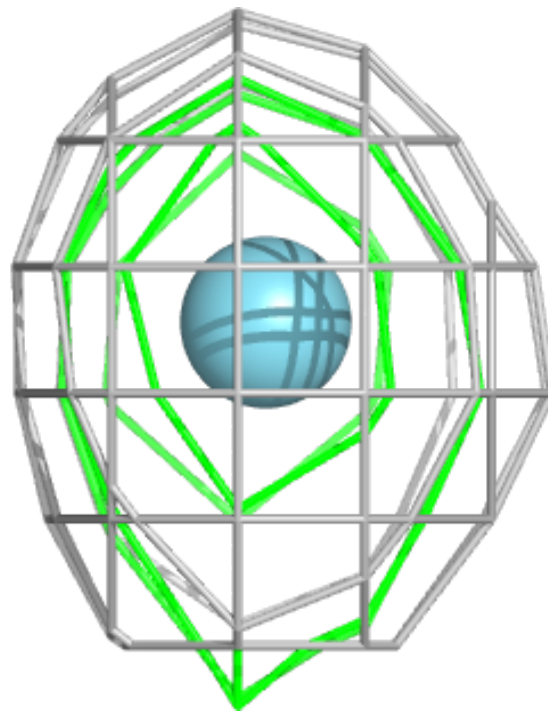

**Electron density around AR A 323:**

$2mF_o-DF_c$  (at 0.7 rmsd) in gray  
 $mF_o-DF_c$  (at 3 rmsd) in purple (negative)  
and green (positive)

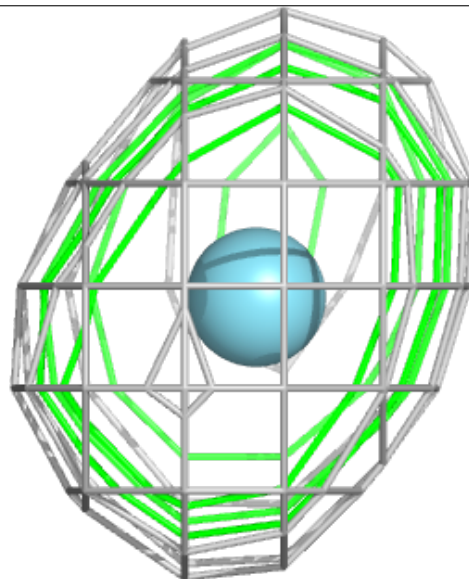
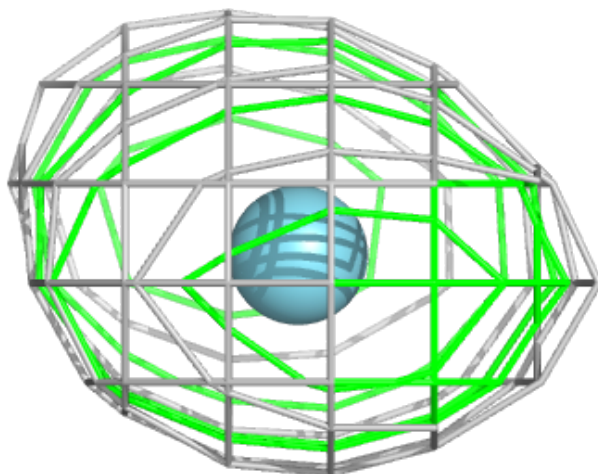
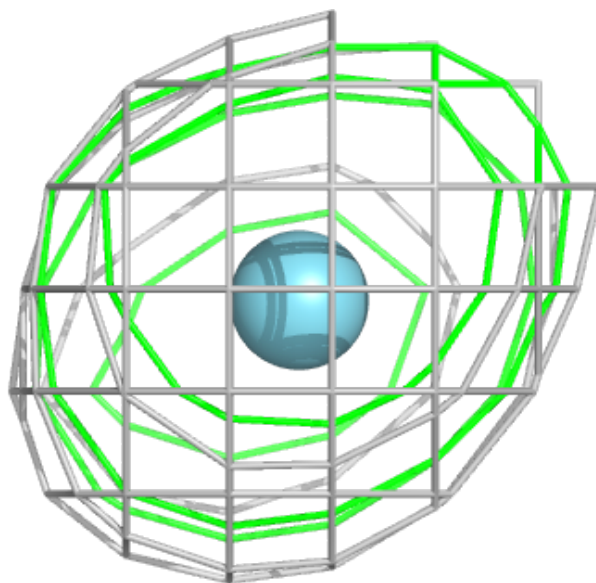

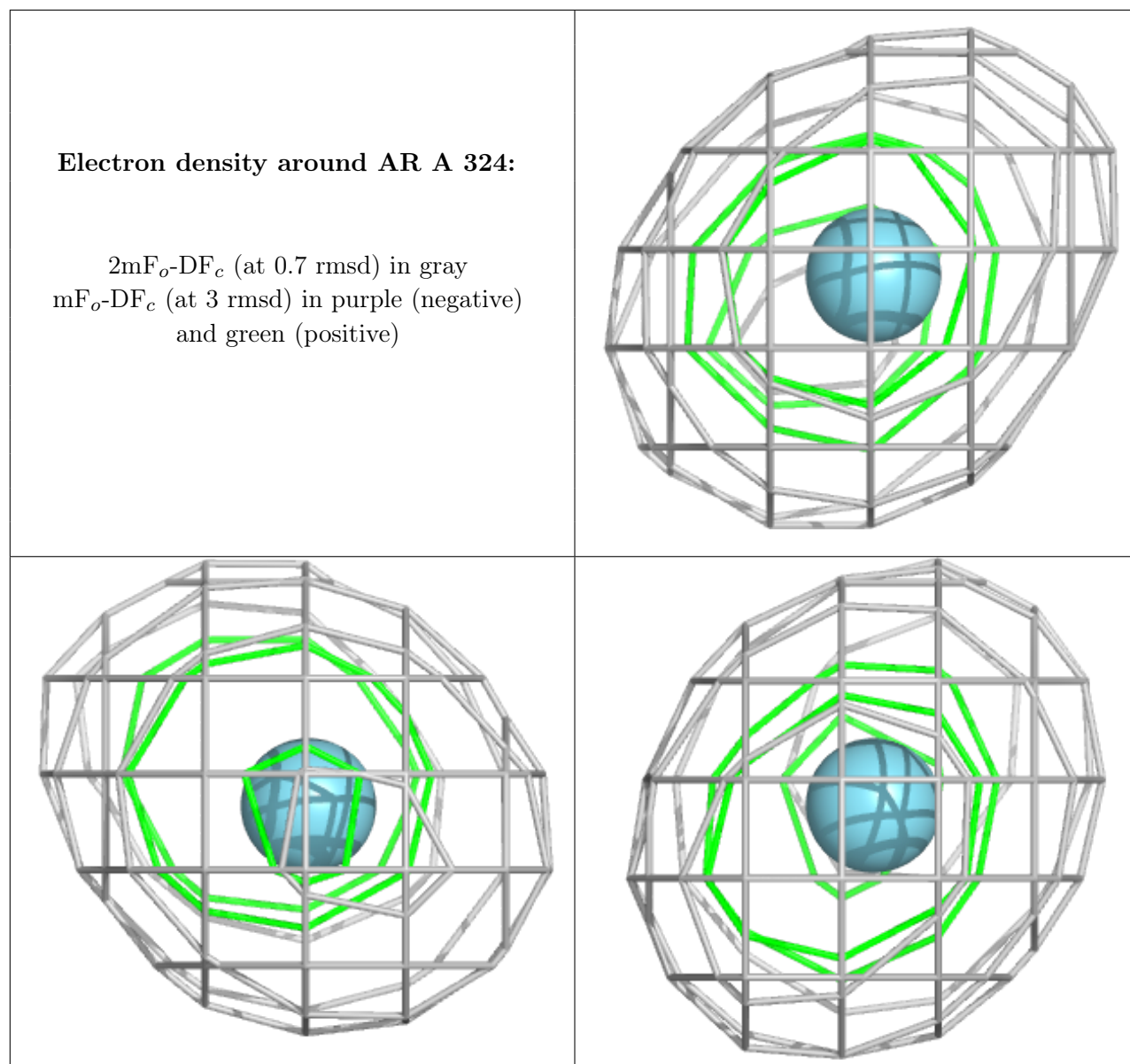

## 6.5 Other polymers [i](#)

There are no such residues in this entry.